

LARGE-SIZED BIG BORE HEAVY DUTY TURNING CENTER  
WITH UP TO 560MM SPINDLE BORE

# PUMA

**PUMA** 1000/M

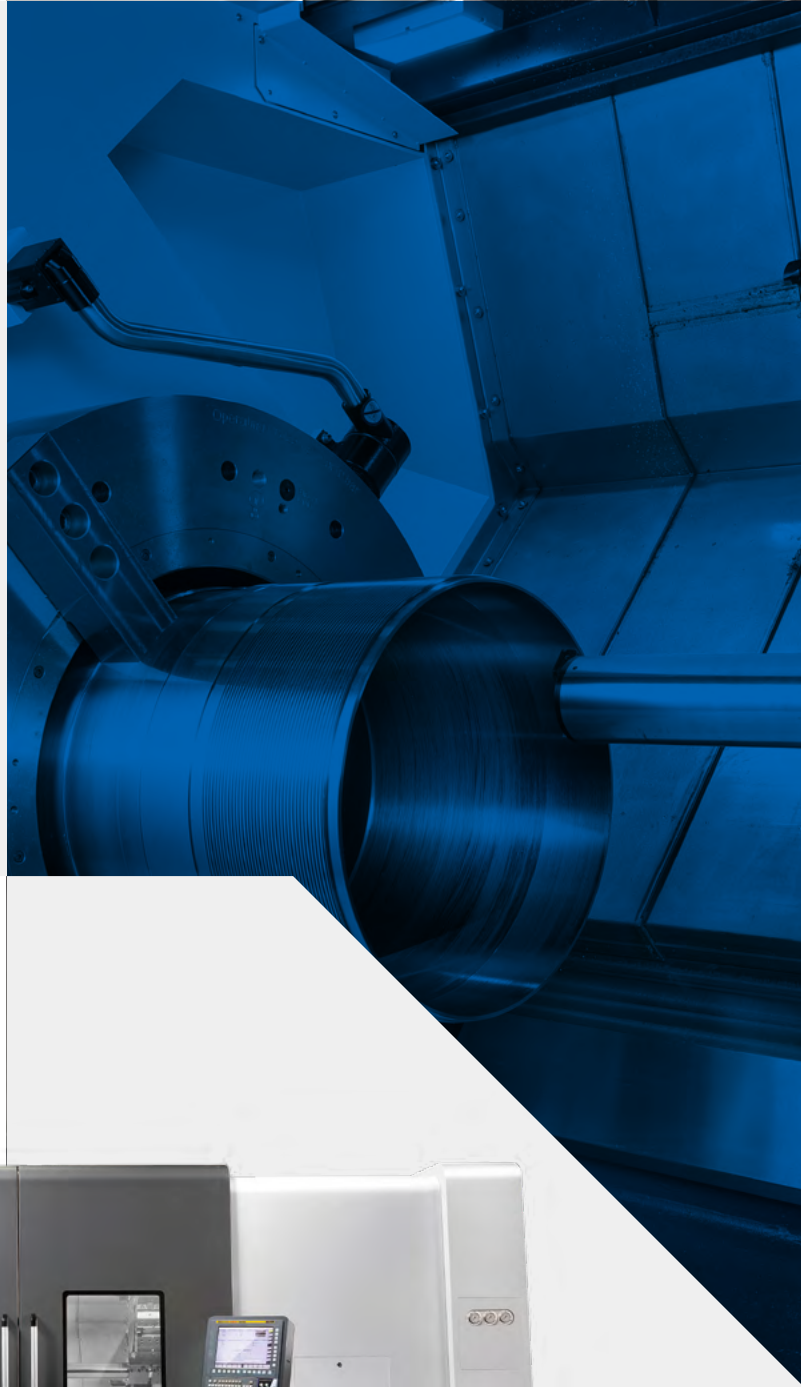

# PUMA 1000 SERIES

---

The PUMA 1000 series machines are large horizontal turning centers, optimized for the machining of pipe and flange type parts typically found in the oil & gas, power generation, aerospace and construction and shipbuilding industries.

The machines deliver powerful machining capability and feature a two-step gearbox and high torque motors together with a rigid box guideway structure. Highly rigid servo-driven turrets ensure fast and stable tool rotation and impressive stability required for heavy-duty cutting and high accuracy milling operations.





## IDEAL SPECIFICATION FOR MACHINING LARGE WORKPIECES

- The Number One choice for machining large parts and undertaking powerful cutting operations with a maximum turning diameter of  $\text{Ø}1000$  mm (39.4inch), a machining length of 2,000 mm (78.7inch) and maximum spindle torque 12,040 N-m (8,885.5 ft lbs).

## PROVIDING A RANGE OF PIPE MACHINING SOLUTIONS

- Maximum  $\text{Ø}560$  mm ( $\text{Ø}22.0$  inch) big bore spindle enables the machining of parts longer than the distance between centers.
- PUMA 1000 machines are capable of performing threading work.

## IMPROVED PRODUCTIVITY

- Turret indexing is possible, even with a long boring bar ( $\text{Ø}100$  x L1000 mm ( $\text{Ø}3.9$  x 39.4inch)) mounted on the recently-designed high-rigidity turret that delivers improved machining stability and productivity.

# BASIC STRUCTURE

A 45° slant bed with hardened and ground box guideways is made from Meehanite cast iron. The basic structure is designed to minimize deformation from occurring during heavy duty machining.

## Structural stability of slant bed and box guideway

The PUMA 1000 series has been developed with years and years of accumulated engineering know-how and experience of designing and manufacturing large capacity Puma lathes behind it. PUMA 1000's rigid structure guarantees process reliability and efficient machining.

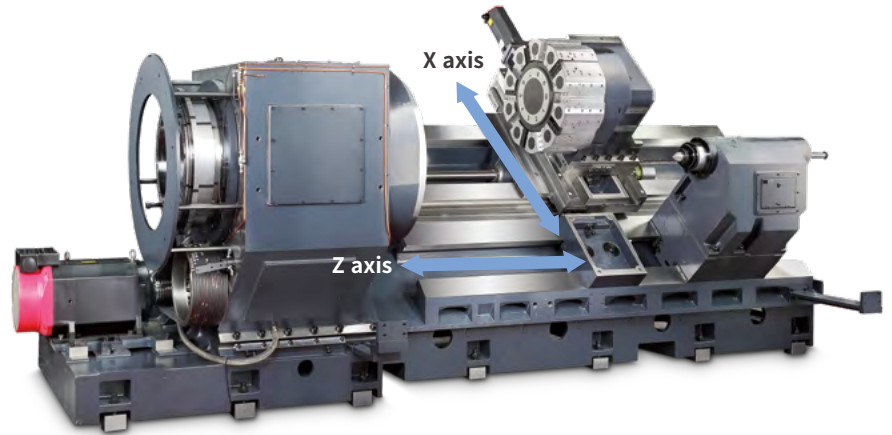

## MACHINING AREA

PUMA 1000 machines are configured for machining pipes with big bores typically found in the oil and gas industry, and in sectors requiring large machined parts.

### Spacious working envelope for machining large workpieces

PUMA 1000 machines' large working envelopes, big bore spindles and large swing over table enables the machining of big steel rollers, large diameter flanges, and long shafts found in ships etc.

#### Max. turning diameter

**Ø1000 mm**  
ø39.4 inch

#### Max. turning length\*

**2040 mm**  
80.3 inch

\* Max. turning length varies and depends on the chuck selected.

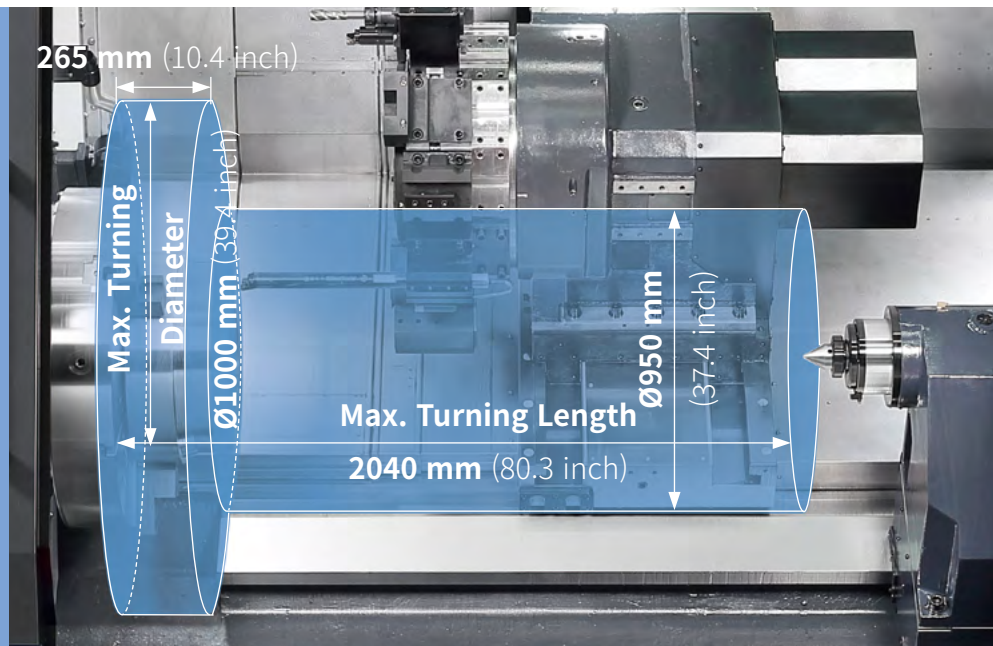

To enable the mounting of large workpieces using cranes, PUMA 1000 machines feature wide front doors.

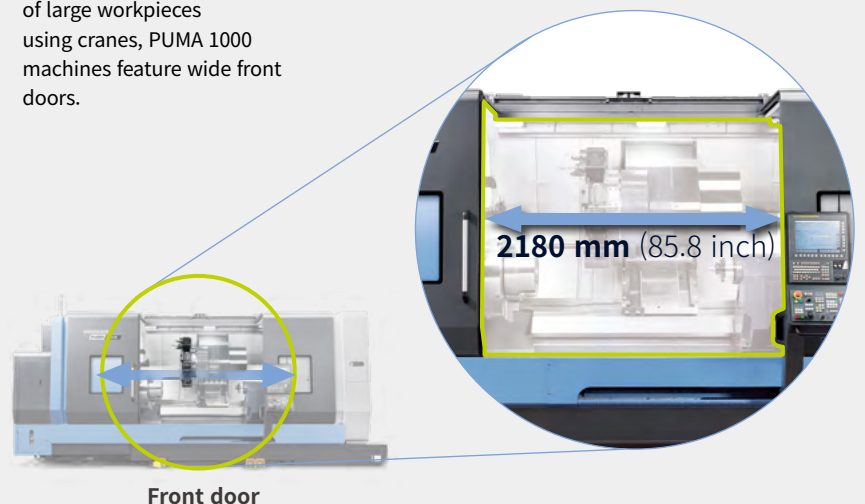

Front door

# SPINDLE

Powerful motors and large spindle bores  $\varnothing 560$  mm ( $\varnothing 22.0$  inch) enable Puma 1000 turning centers to machine shafts and valves etc., that are longer than the distance between centers.

## Extra large diameter spindle through hole (bore)

PUMA 1000 machines have big spindle-through-hole capacities - up to  $\varnothing 560$  ( $\varnothing 22$ " )mm - and powerful spindles - up to 75kW (100.1Hp) - with two-step gearboxes that deliver unrivalled performance.

### Max. spindle through hole diameter

PUMA 1000A/MA {1000B/MB}

**$\varnothing 375$  { $\varnothing 560$ }** mm  
 $\varnothing 14.8$  { $\varnothing 22.0$ } inch

### Max.spindle power (30min/cont.)

**75/60** kW  $\varnothing 14.8$  { $\varnothing 22.0$ } inch

### Max. spindle speed

PUMA 1000A/MA {1000B/MB}

**500 {300}** r/min

### Max. spindle torque

PUMA 1000A/MA {1000B/MB}

**11011 {12040}** N · m  
8126.1 {8885.5} ft-lb

# TAILSTOCK

Highly-rigid programmable tailstocks are available as standard to provide stable support for machining long workpieces.

## Programmable tailstock with built-in dead center

The tailstock, supported by hardened and ground boxed ways, comprises a one-piece structure with the machine base, ensuring high structural rigidity. Its built-in type dead center supports heavy workpieces while maintaining machining accuracy.

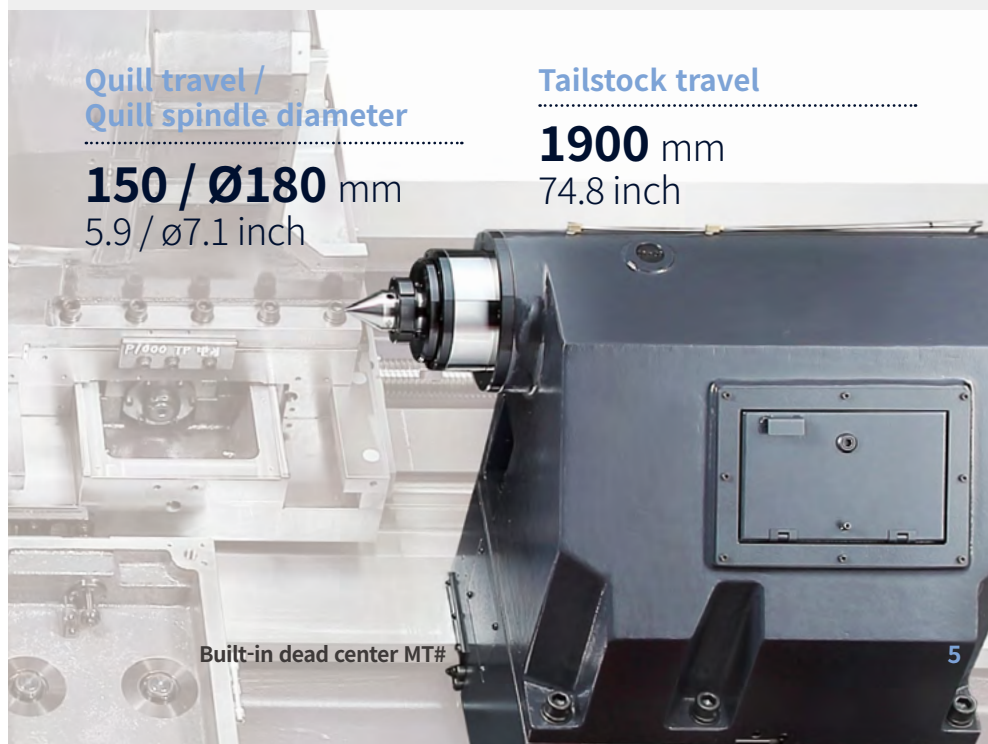
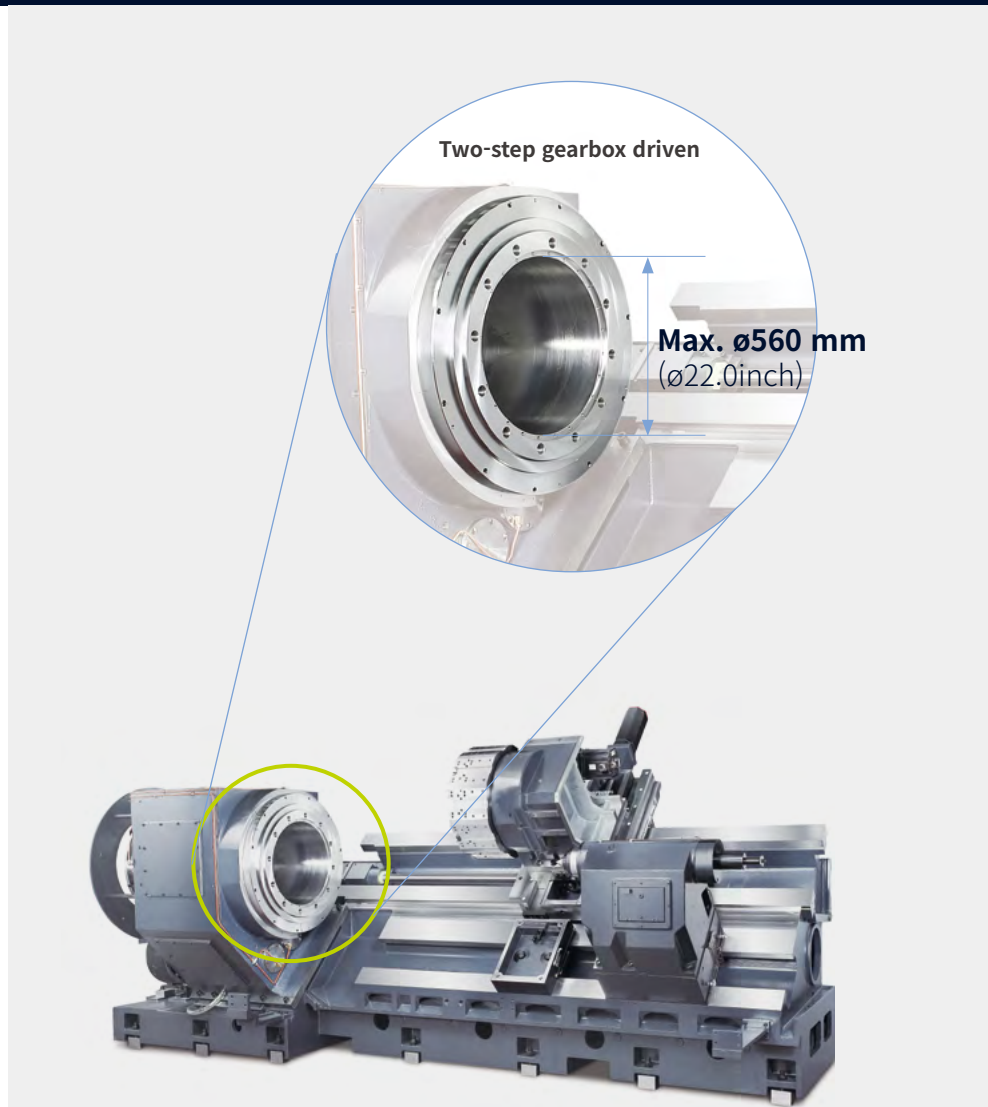

### Quill travel / Quill spindle diameter

**150 /  $\varnothing 180$**  mm  
5.9 /  $\varnothing 7.1$  inch

### Tailstock travel

**1900** mm  
74.8 inch

# TURRET

Strong, large-sized and rigidly-built servo-driven turrets ensure fast and stable tool rotation, and best-in-class process reliability for heavy-duty machining and milling operations.

## Servo-driven turret

The powerful servo-driven turret provides accurate location control and quick and stable tool exchange.

The width of the turret has been doubled, compared to PUMA 600/700/800 machines, ensuring high process stability - especially required when machining long parts and during heavy-duty operations.

## No. of tool station

PUMA 1000

**10** stations (for turning only)

## Max. OD tool size

**32 X 32** mm  
1.25 X 1.25 inch

## Max. Boring Bar Size

**Ø80** mm  
ø3.1 inch

## Tool holder type

PUMA 1000M

**BMT85P**

## No. of tool station

**12** stations

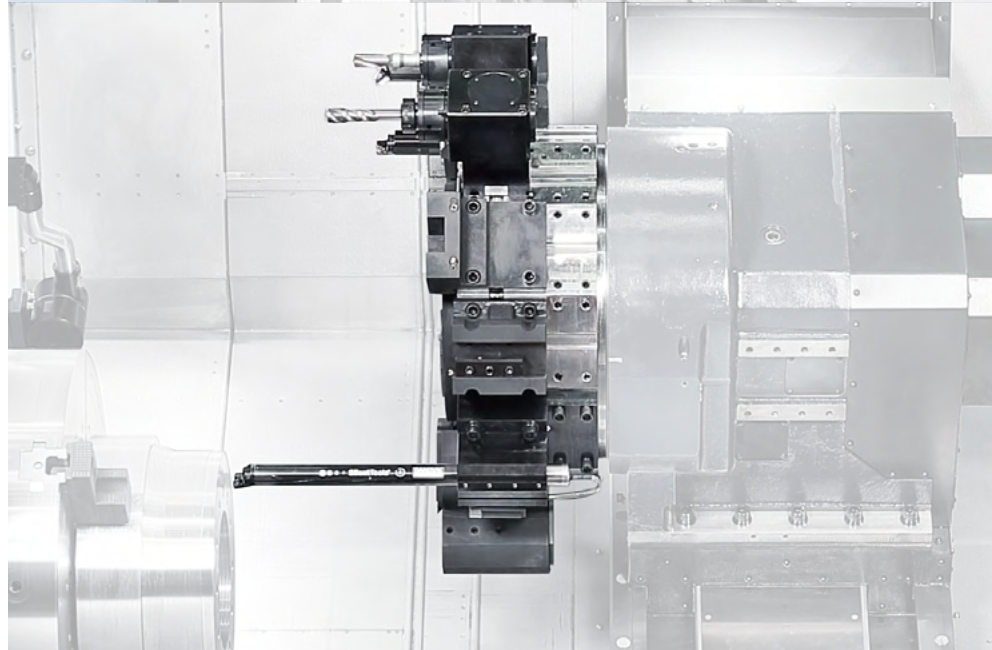
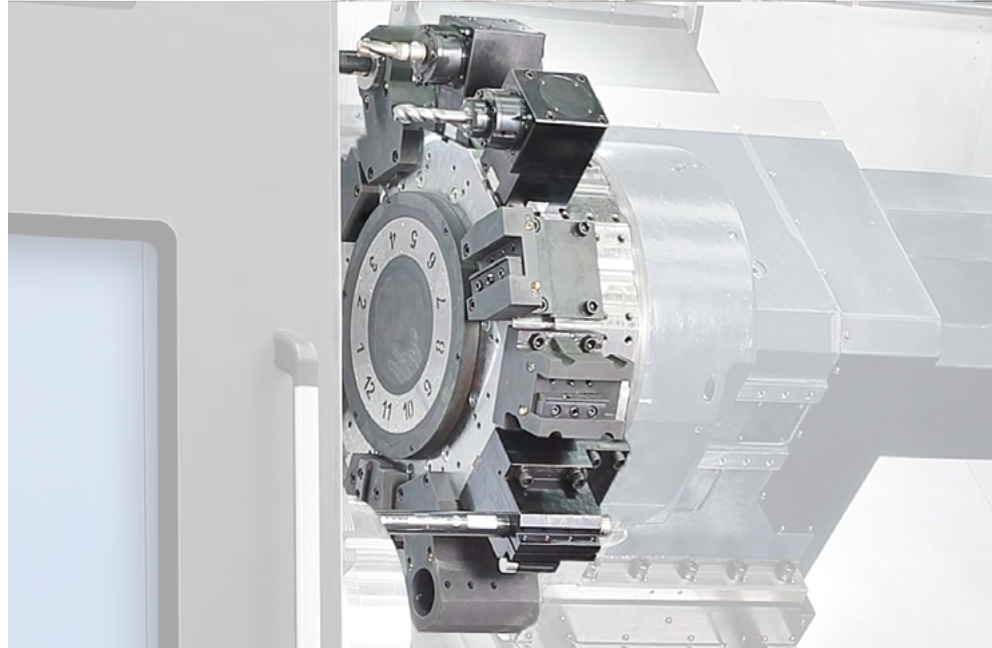

# STANDARD | OPTIONAL SPECIFICATIONS

A range of options is available to suit individual requirements.

Description	Features			PUMA1000A	PUMA1000B
				2 axis / M	2 axis / M
Chuck (Left / Right)	None			●	●
	32 Inch			○	X
	40 Inch			X	△
Jaws (Left / Right)	Soft Jaws			○ <sup>1)</sup>	△
	Hardened & Ground Hard Jaws			○	△
Chucking Option	Single Pressure Chucking			●	X
	Dual Pressure Chucking			○	X
	Cuck Clamp Confirmation			○	X
Steady Rest*	Dimension	Pressure	ø100~ø410 (K5.1Z)	○	○
			ø135~ø460(K6Z)	○	○
			ø215~ø510(K6.1Z)	○	○
	Type (Programmabl)	Single	○	○	
		Twin	○	○	
		Double	○	○	
Tailstock	Programmable Dead Center			●	●
Coolant Pump	4.5 bar			●	●
	7/10/14.5/28/70 bar			○	○
Coolant Options	Oil Skimmer			○	○
	Water soluble Coolant Chiller***			○	○
	Coolant Pressure Switch			○	○
	Coolant Gun			○	○
Chip Disposal	Chip Conveyor_Side Type			○	○
	Chip Bucket			○	○
	Air Blow			○	○
	Mist Collector Interface (Duct only)			○	○
	Integrated Mist Collector			○	○
Measurement & Automation	Tool Setter	Auto		○	○
	Auto Door			○	○
Optional devices	Tool Load Monitoring			●	●
	Signal Tower			○	○
	Air Gun			○	○
	Auto Power Off			○	○
	Air Unit for Air Cuck	Single	○		○
		Twin	○		○
	Quick change tooling(CAPTO)			○	○
Sketch-turn S/W			○	○	
Customized Special Option	STEADY REST	PROGRAMMABLE	RX-6.1 (Ø250 ~ Ø685)	○	○
	CHUCK	40INCH (OUT DIAMETER Ø1000)		○	○
		TWIN CHUCKING **		○	○
	Coolant level switch : Sensing level - Low			○	○
Standard Accessories	FOUNDATION BOLT FOR ANCHORING			●	●

\* Please contact DN Solutions to select detailed steady rest specifications

● Standard ○ Optional X Not applicable

\* When using a semi-synthetic type or synthetic type, contact our sales representative or service center in advance.

1) Each chuck comes with 1set of soft jaws as standard. \*\* Please contact DN Solutions to select detailed Twin Chucking specification.

\*\*\* Technical consultation is mandatory for the chilling of non-water soluble coolant



Fire Safety Precautions

There is a high risk of fire when using non-water-soluble cutting fluids, processing flammable materials, neglecting the controlled and careful use of coolants and modifying the machine without the consent of the manufacturer. Always check the SAFETY GUIDELINES carefully before using the machine.

# PERIPHERAL EQUIPMENT

## Long boring bar OPTION

The long boring bar option allows customers to machine deep holes quickly and easily to minimize cycle times. Please consult DN Solutions for details.

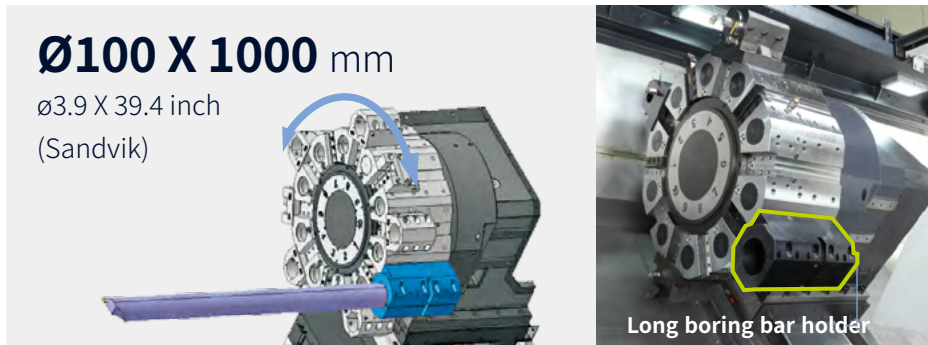

## Twin chucking OPTION

For more stable pipe threading processes, the twin chucking option (manual or pneumatic) is available. Please consult with DN Solutions for details.



## Steady rest OPTION

For turning extremely long parts various types of hydraulic steady rests (Single, Double or Twin) are available.

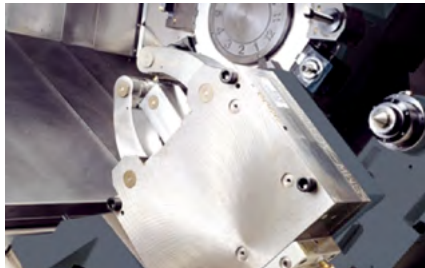

## Auto tool setter OPTION

Best practice for shaft machining, the pocket of the chuck cover accommodates the overhang of the tool, minimizing interference and enhancing tool usability.



## Quick change CAPTO OPTION

The quick change tool system simplifies tool change operations. Recommended for customers who need to change tools frequently or to reduce set-up times.

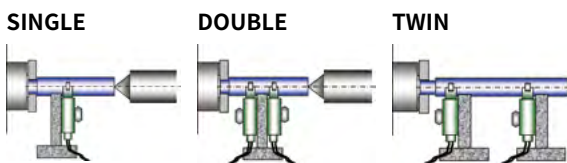

## Coolant tank

DN Solutions's ergonomic roller coolant tank design allows customers to easily replace and refill coolant. Rollers on the coolant tank allows them to be taken out and put back into the machine like a drawer unit.



## Chip conveyor OPTION



### Hinged belt type\*

Most common type of chip conveyor. Appropriate for steel materials generating chips over 30mm.

### Drum filter type\*\*

Chip conveyor with a magnet: Appropriate for machining cast iron and the generation of fine chips.

Chip conveyor type	Material	Carbon steel)			Cast iron		Aluminium		
		Long	Short	Needle	Short	Sludge	Long	Short	Needle
Hinged belt type*		○	△	X	△	X	○	△	X
Scrapper type	Normal	X	○	△	○	△	X	△	X
	Magnetic	X	○	○	○	○	-	-	-
Drum filter type**	Hinged type	○	△	X	△	X	○	△	X
	Scrapper	X	○	△	○	△	X	○	△

○ : Suitable, △ : Possible, X : Not suitable

## Coolant Chiller (recommended) OPTION

A coolant chiller is recommended to help prevent temperature rises and to reduce thermal deformation when using a water-insoluble coolant or a high-pressure coolant system (i.e., power over 1.5kW).

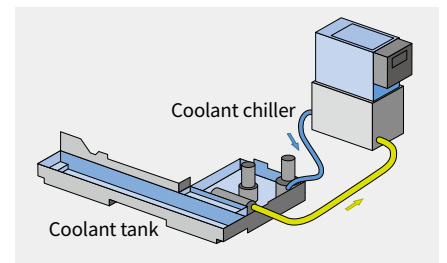

# DN SOLUTIONS FANUC i PLUS

DN Solutions Fanuc i Plus maximizes customer productivity and convenience.

## 15" Screen + New OP

DN Solutions Fanuc i Plus' operation panel enhances operating convenience by incorporating common-design buttons and layout. It features a Qwerty keyboard for fast and easy data input and operation.

### DN Solutions Fanuc i Plus

- 15-inch color display
- Intuitive and user-friendly design

### USB and PCMCIA card QWERTY keyboard

- EZ-Guide i standard
- Ergonomic operator panel
- 2MB Memory
- Hot keys



### iHMI touchscreen OPTION

iHMI provides an intuitive interface that uses a touchscreen for quick and easy operation.

### Range of applications

Providing various applications related to planning, machining, improvement and utility, for customer convenience.

### SKETCH-TURN OPTION

#### DN Solutions Conversational programming software for PC

- Easy to learn for beginners
- Time savings in programming
- Reduce processing cycle time



## NUMERIC CONTROL SPECIFICATIONS

FANUC

Division	Item	Specifications	2-Axis	M
			DN Solutions Fanuc i Plus	DN Solutions Fanuc i Plus
Controlled axis	Controlled axes		2(X,Z)	3(X,Z,C)
	Simultaneously controlled axes		2 axes	3 axes
Data input/output	Fast data server		○	○
	Memory card input/output		●	●
	USB memory input/output		●	●
	Larger capacity memory_2GB	Note *2) Available Option only with 15" Touch LCD (iHMI Only)	○ *2)	○ *2)
Interface function	Embedded Ethernet		●	●
	Fast Ethernet		○	○
	Enhanced Embedded Ethernet function		●	●
Operation	DNC operation	Included in RS232C interface.	●	●
	DNC operation with memory card		●	●
Program input	Workpiece coordinate system	G52 - G59	●	●
Feed function	AI contour control I	G5.1 Q_ , 40 Blocks	○	○
	AI contour control II	G5.1 Q_ , 200 Blocks	○	○
	EZ Guidei (Conversational Programming Solution)		●	●
Operation Guidance Function	iHMI with Machining Cycle	Note *1) Only with 15" Touch LCD standard	○ *1)	○ *1)
	EZ Operation package		●	●
Setting and display	CNC screen dual display function		●	●
Network	FANUC MTConnect		✦	✦
	FANUC OPC UA		✦	✦
Others	Display unit	15" color LCD	●	●
		15" color LCD with Touch Panel	○	○
	Part program storage size & Number of registerable programs	640M(256KB)_500 programs 5120M(2MB)_1000 programs	X ●	X ●

Network: FANUC MTConnect and FANUC OPC UA available.

● Standard ○ Optional X N/A ✦ Available

# CONVENIENT OPERATION

## SIEMENS S828D

### 15.inch display + New OP

Siemens 828D' operation panel enhances operating convenience by incorporating common-design buttons and layout. It features a Qwerty keyboard for fast and easy data input and operation.

- 15.6 inch display
- USB (standard)
- QWERTY keyboard



### Convenient conversational functionality

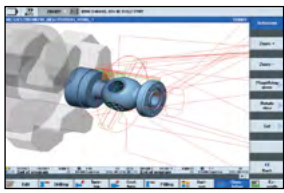

**Cutting and operation support function**  
This function shows a cutting and tool path simulation in real-time.

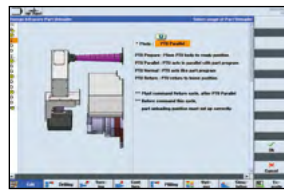

Shop-turn mode  
[various]  
[attachments]

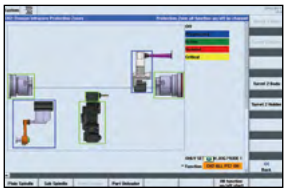

[Custom]  
[Protection zones]

#### Operation safety function

Protection Zone Synchronized Actions checks the interference between the turret and the spindle to prevent collisions caused by operator error.



[offset]  
[operating parameter]  
[TC service]

#### Maintenance and service convenience function

Maintenance and service of major equipment and peripheral devices, including the timer and parts counter settings can be easily undertaken.

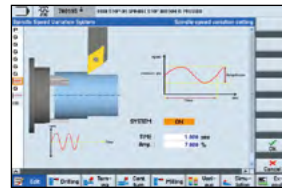

[various]  
[attachment]  
[DSSV]

#### Machining accuracy improvement

The NC controls spindle speed at an optimal level for precision threading and turning, making it possible to automatically improve surface roughness.

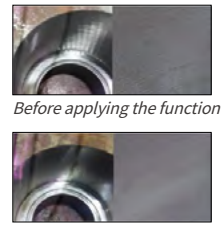

Before applying the function  
After applying the function

## NUMERIC CONTROL SPECIFICATIONS

SIEMENS

Division	Item	Specifications	2-Axis S828D	M S828D	S S828D	MS S828D	Y S828D	SY S828D
Controlled axis	Controlled axes		X,Z,SP	X,Z,C,R	X,Z,C,C2,B	X,Z,C,R,C2,B	X,Z,C,R,Y	X,Z,C,R,C2,Y,B
	Simultaneously controlled axes		4 axes	4 axes	4 axes	4 axes	4 axes	4 axes
Data input/output	Memory card input/output		X	X	X	X	X	X
	USB memory input/output		●	●	●	●	●	●
Interface function	Ethernet (X130)		○	○	○	○	○	○
	On network drive (without EES option, Extcall)		●	●	●	●	●	●
Operation	On USB storage medium, e.g. memory stick (without EES option, Extcall)		●	●	●	●	●	●
	Workpiece coordinate system	G54 - G59, G507 - G599	●	●	●	●	●	●
Feed function	Advanced surface		X	X	X	X	X	X
	Top surface		X	X	X	X	X	X
	Look ahead number of block		1	1	1	1	1	1
Programming & Editing function	3D simulation, finished part		●	●	●	●	●	●
	Simultaneous recording		●	●	●	●	●	●
	DXF Reader for PC integrated in SINUMERIK Operate		○	○	○	○	○	○
Operation Guidance Function	Shopturn		●	●	●	●	●	●
	EZ Operation package		●	●	●	●	●	●
Setting and display	Operation via a VNC viewer		●	●	●	●	●	●
	MTConnect OPCUA		⊗	⊗	⊗	⊗	⊗	⊗
Others	Display unit	15.6" color display with touch screen	●	●	●	●	●	●
	Part program storage size	CNC user memory 5MB	●	●	●	●	●	●
		CNC user memory 100 MB	○	○	○	○	○	○
		CNC user memory 6GB	X	X	X	X	X	X
		CNC user memory 40GB (with PCU or IPC)	X	X	X	X	X	X
		CNC user memory without limit (Execution from external storage devices)(EES / Using by USB or Network)	○	○	○	○	○	○
		HMI user memory for CNC part program 6GB	X	X	X	X	X	X

● Standard ○ Optional X N/A ⊗ Available

# STABLE THREADING PERFORMANCE

2-axis\* through to Y-axis models are capable of threading work.

\* In order to re-machine threads or perform arbitrary speed threading on a 2-axis machine, additional options/accessories have to be selected.

## Threading repair function

This standard Fanuc NC function allows users to repair threads even when the original program is no longer available or cannot be accessed available.



## Arbitrary speed threading

OPTION

This function allows users to control and override spindle speeds in order to produce/replicate the best thread quality.

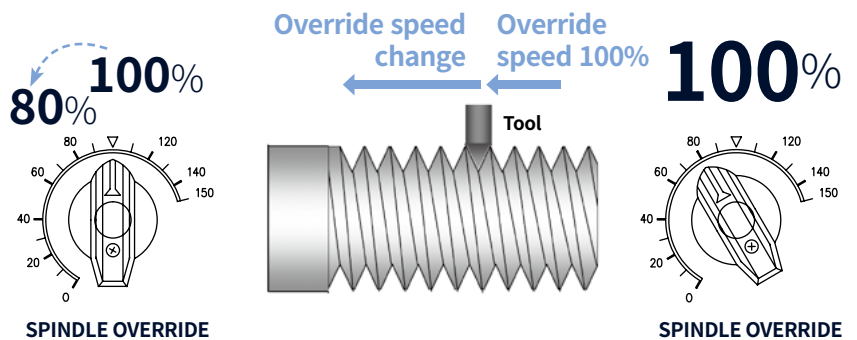

## Re-machining function

This function is included within the arbitrary speed threading software and enables customers to re-machine damaged threads using existing programs.

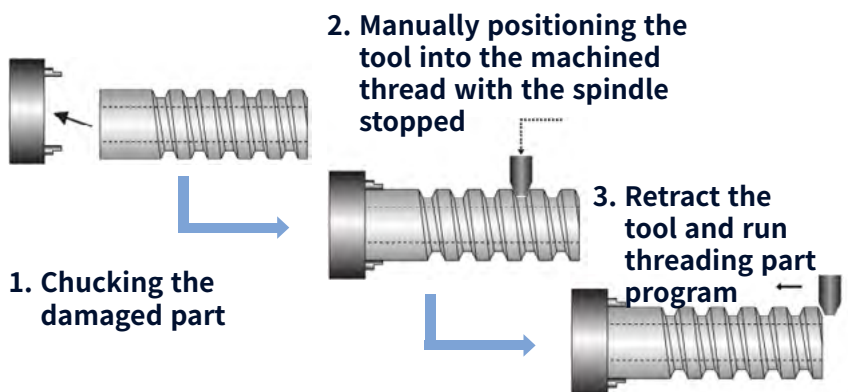

# POWER | TORQUE

FANUC

## PUMA 1000A/MA

Max. spindle speed : **500** r/min

Max. power : **75/60** kW  
100.6 / 80.5 HP

Max Torque : **11011** N·m  
8126.1 ft-lb

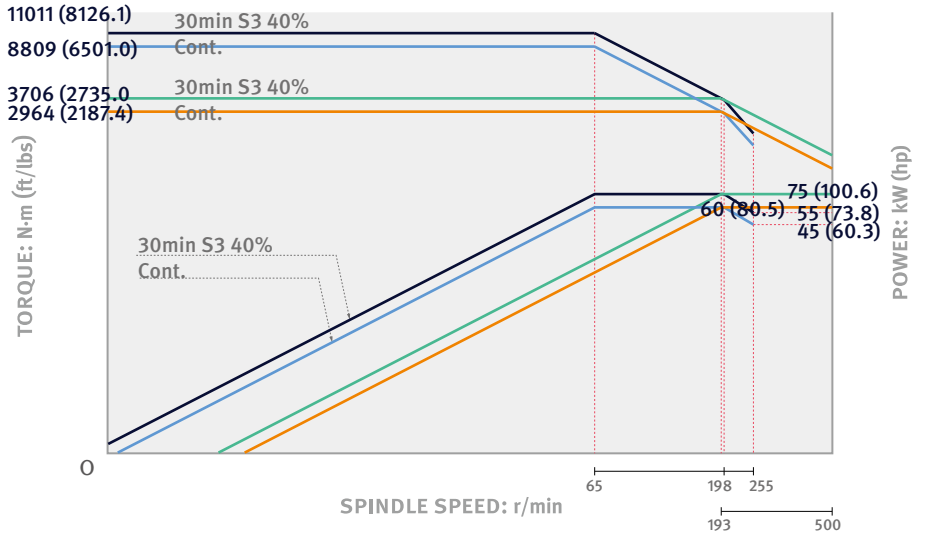

## PUMA 1000B/MB

Max. spindle speed : **300** r/min

Max. power : **75/60** kW  
100.6 / 80.5 HP

Max Torque : **12040** N·m  
8885.5 ft-lb

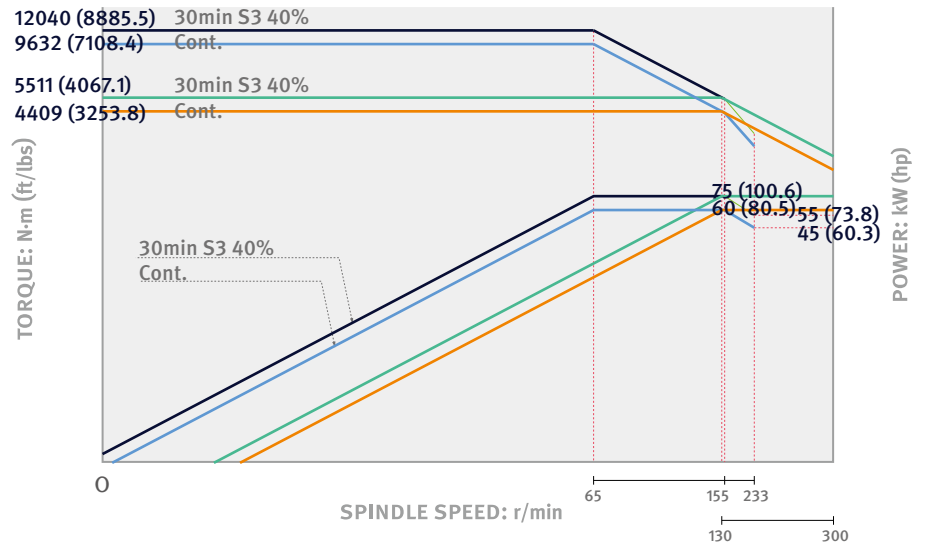

## Rotary tool

Max. spindle speed : **3000** r/min

Max. power : **12** kW  
16.1 HP

Max Torque : **152** N·m  
112.2 ft-lb

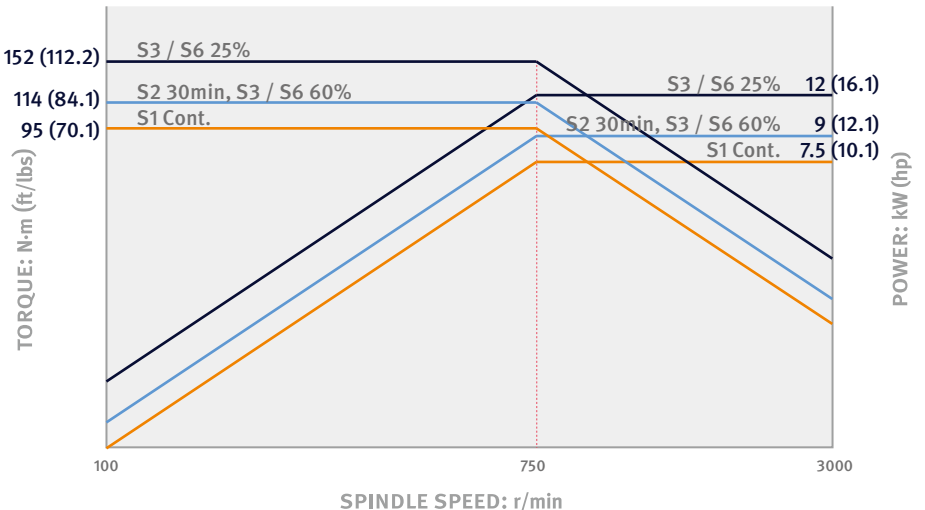

# EXTERNAL DIMENSIONS | TOOL INTERFACE

Unit : mm (inch)

TOP

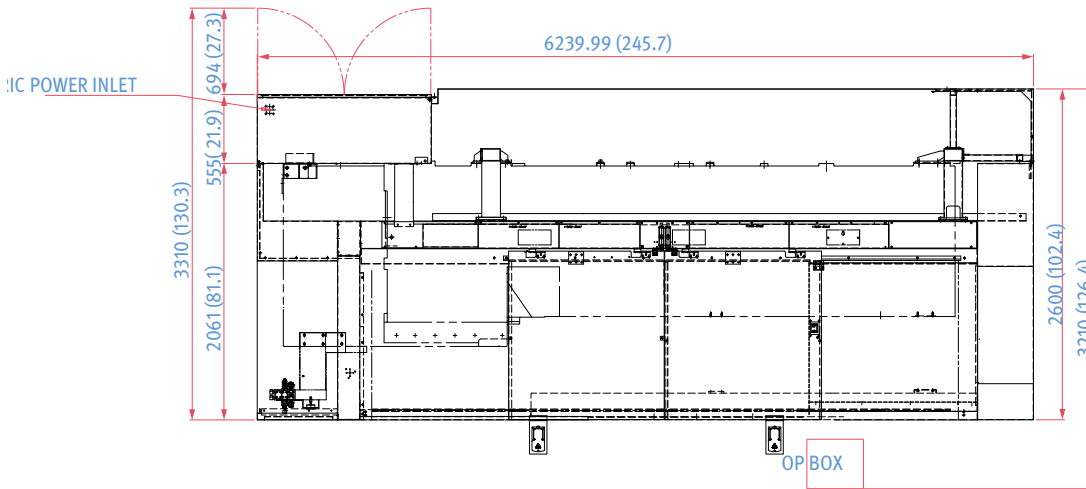

FRONT

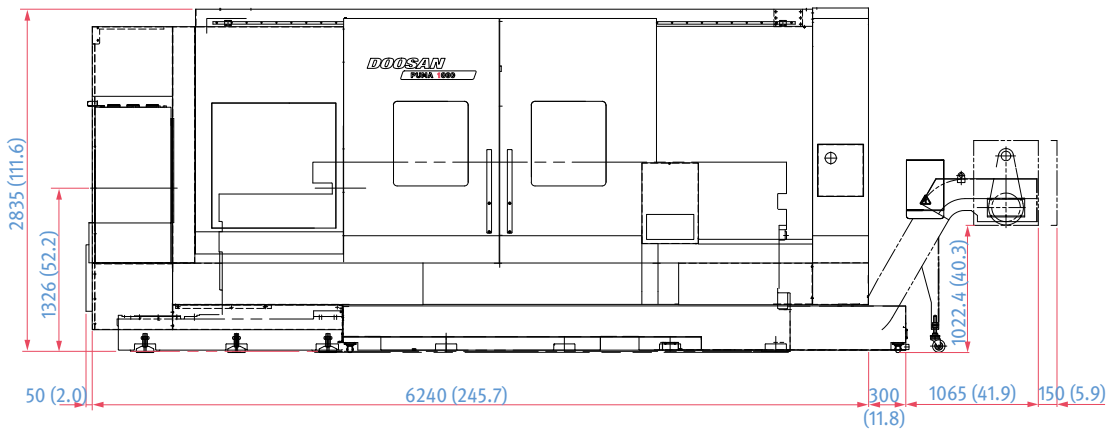

\* Some peripheral equipment can be placed in other places.

## TOOL INTERFACE

PUMA 1000 (2-axis)

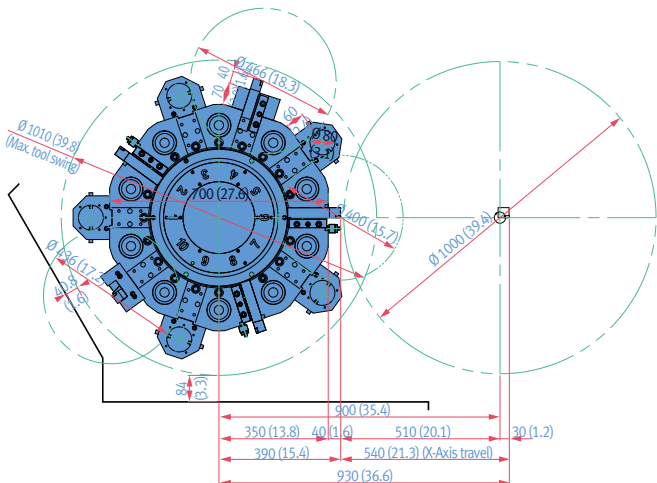

PUMA 1000M (3-axis)

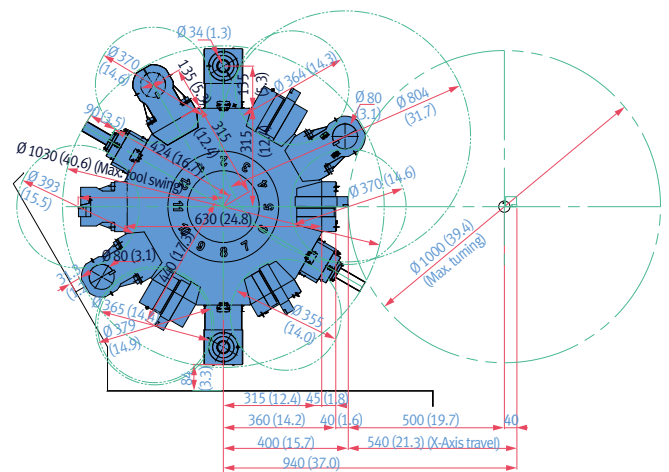

# TOOLING SYSTEM

Unit : mm (inch)

## PUMA 1000

### Standard

\* ( ) Supply quantity

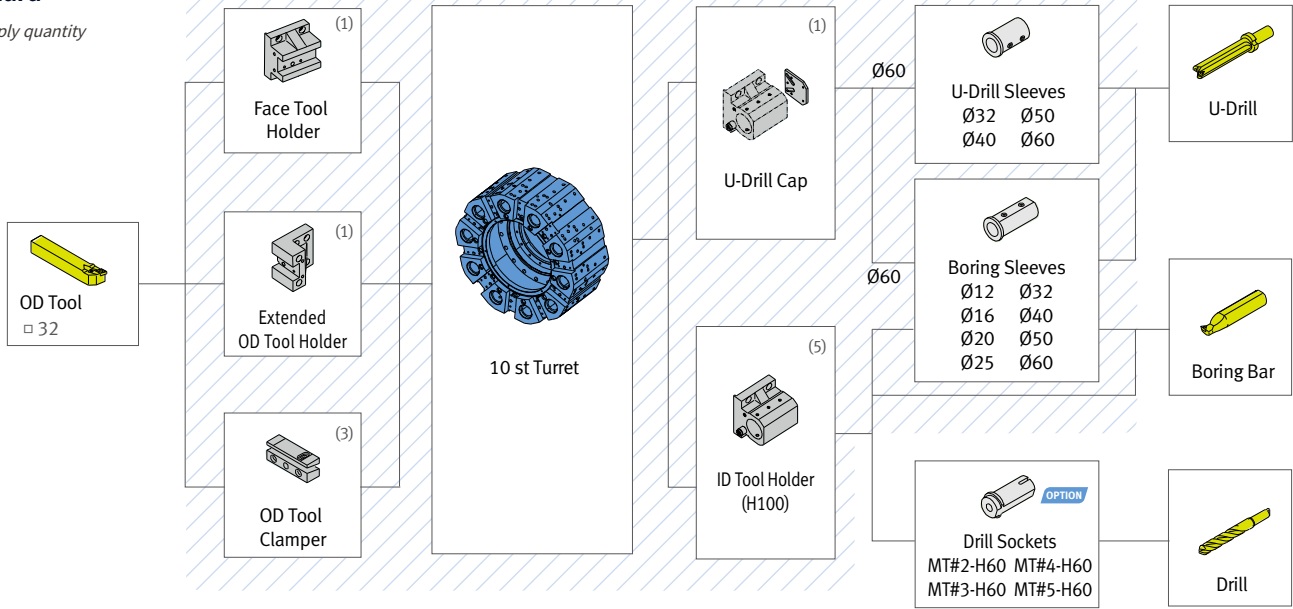

## PUMA 1000M

### Standard

\* ( ) Supply quantity

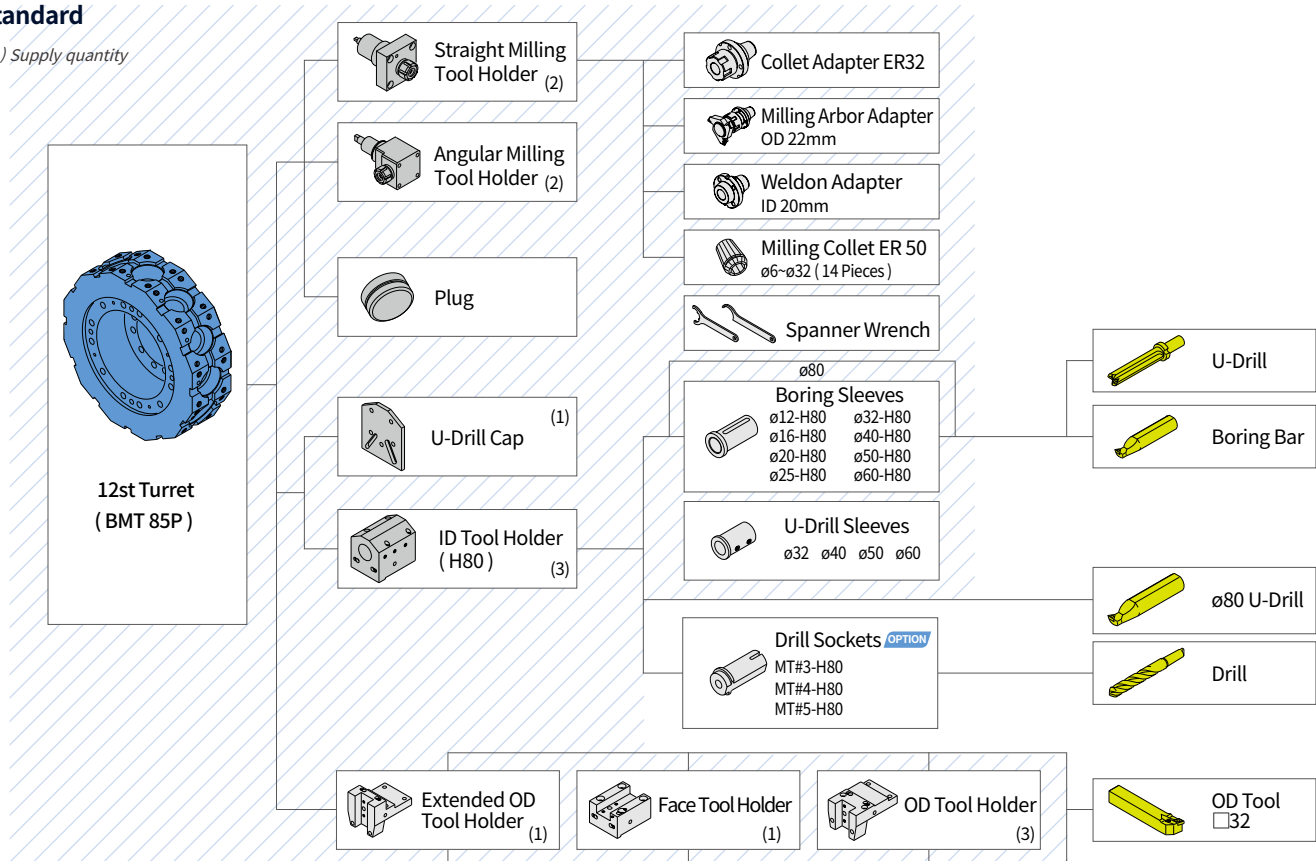

# WORKING RANGE DIAGRAM

PUMA 1000A / B

Unit : mm (inch)

## OD TOOL HOLDER

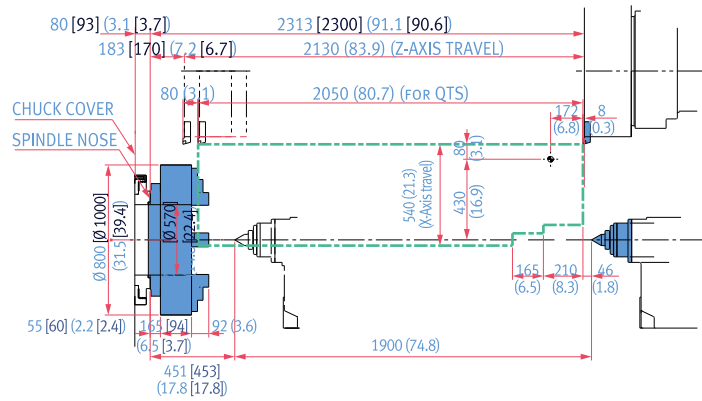

## ID TOOL HOLDER

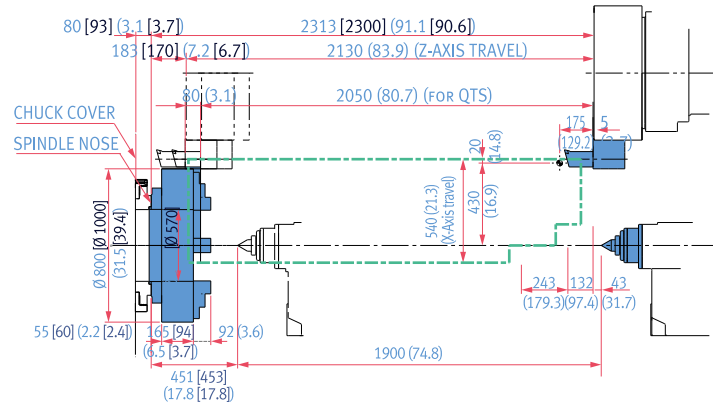

## FACE TOOL HOLDER

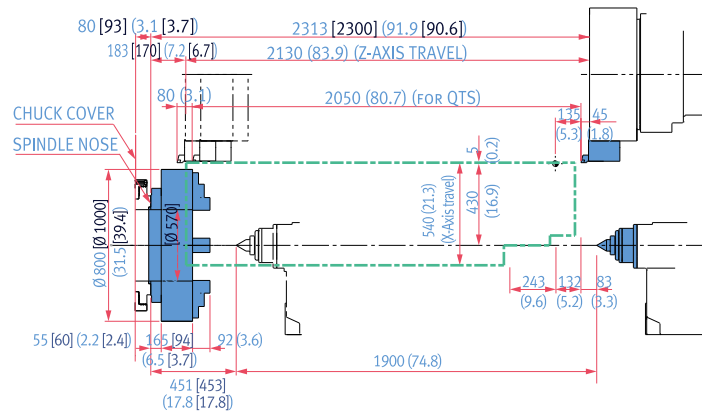

## EXTENDE OD TOOL HOLDER

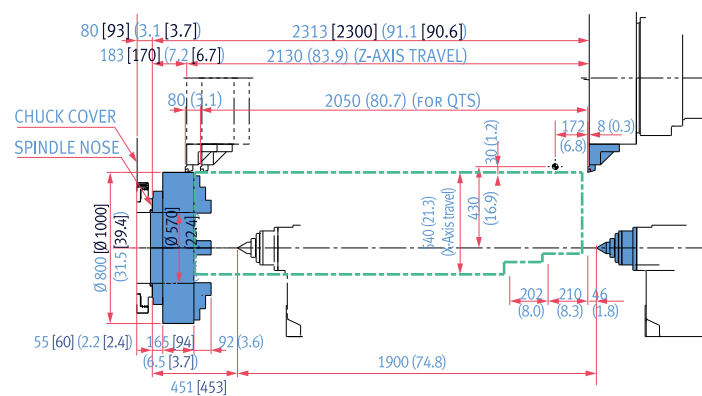

# WORKING RANGE DIAGRAM

PUMA 1000MA / MB

Unit : mm (inch)

OD TOOL HOLDER

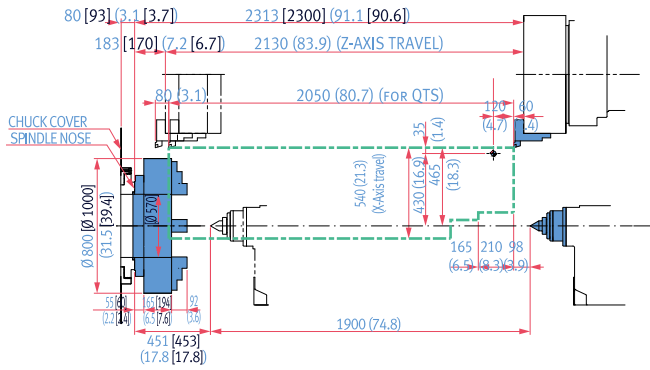

OD TOOL HOLDER

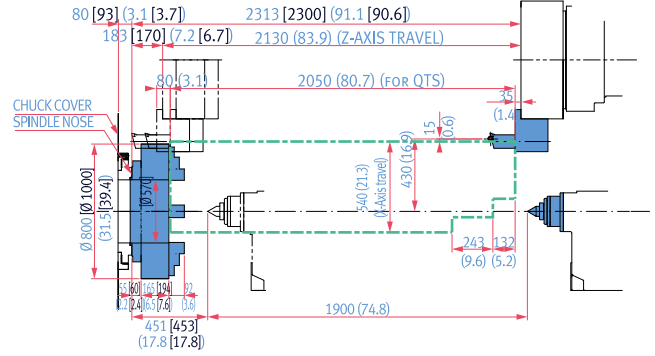

OD TOOL HOLDER

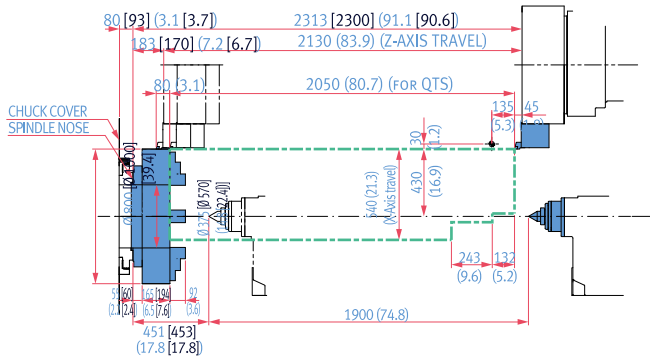

OD TOOL HOLDER

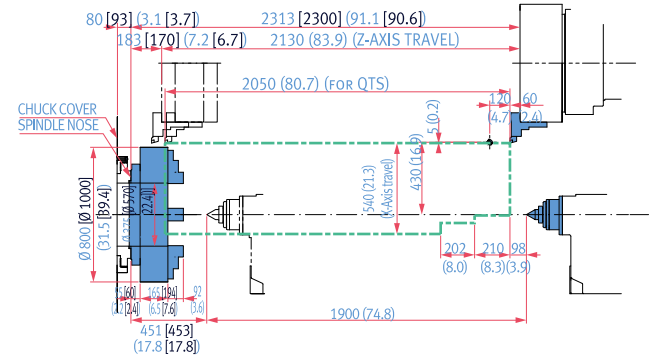

OD TOOL HOLDER

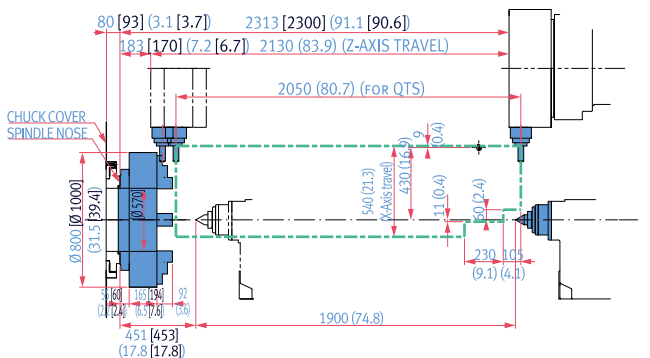

# MACHINE SPECIFICATIONS

**PUMA** 1000 series

Description		Unit	PUMA 1000A [MA]	PUMA 1000B [MB]
Capacity	Swing over bed	mm (inch)	1250 (49.2)	
	Swing over saddle	mm (inch)	950 (37.4)	
	Recom. turning diameter	mm (inch)	800 (31.5)	
	Max. turning diameter	mm (inch)	Ø 1000 (39.4)	
	Max. turning length	mm (inch)	2040 (80.3)	2000 (78.7)
	Chuck size	inch	(ORDER MADE)	
Travels	Travel distance	X-axis	540 (21.3)	
		Z-axis	2130 (83.9)	
	Rapid traverse rate	X-axis	12 (472.4)	
		Z-axis	16 (629.9)	
Spindle	Max. spindle speed	r/min	500	300
	Main spindle motor power (30min./cont.)	kW (Hp)	75 (100.6) / 60 (80.5)	
	Max. spindle torque	N · m (ft-lb)	11011 (8126.1)	12040 (8885.5)
	Spindle nose	ISO	702-4 No.20	702-4 No.28
	Spindle bearing dia.(Front)	mm (inch)	440 (17.3)	700 (27.6)
	Max. Spindle through hole diameter	mm (inch)	Ø375 (14.8)	Ø560 (22.0)
Turret	No. of tool stations	ea	10 [12: BMT85P]	
	OD tool size	mm (inch)	32 x 32 (1.25 x 1.25)	
	Max. boring bar size	mm (inch)	80 (3.0)	
	Turret indexing time (1 station swivel)	s	0.31	
	Max. rotary tool speed	r/min	[3000]	
	Rotary tool motor power (30min./cont.)	kW (Hp)	[9 (12.1) / 7.5 (10.1) ]	
Tailstock	Tailstock travel	mm (inch)	1900 (74.8)	
	Quill diameter	mm (inch)	180(7.1)	
	Quill bore taper	MT	MT#6(Dead)	
	Quill travel	mm (inch)	150(5.9)	
Power Source	Power consumption	kVA	97.54	
Machine Dimensions	Length	mm (inch)	6595 (259.6)	
	Width	mm (inch)	3210 (126.4)	
	Height	mm (inch)	2835 (111.6)	
	Weight	kg (lb)	21000 (46296.4)	23000 (50705.6)
Control	CNC System		DN Solutions Fanuc i Plus {F32i}	

\* Bar working diameter is a nominal size(PUMA 1000A : 375mm / PUMA 1000B: 555mm) we can expect when doing the double chucking operation at both sides of the headstock and using spindle through hole.

\* {} : Option

The DN Solutions promise, MACHINE GREATNESS, has two important meanings. The first is simple: DN Solutions makes great machines. The second is a challenge to our end-users. With a product line that is this comprehensive, accurate and reliable, we equip our customers to machine greatness. **The big question: *Why should you choose DN Solutions over other options?***

Here's why...



**MACHINE  
GREATNESS™**



WHAT YOU MAKE AND HOW YOU MAKE IT MATTERS—SO MAKE IT  
GREAT WITH DN SOLUTIONS.

### UNBEATABLE MACHINES

You won't find a more comprehensive range or a better combination of value, performance and reliability anywhere else.

### ROBUST PRODUCT LINE

We offer an impressive range of machine models and hundreds of configurations. Whatever your machining needs and requirements, there's a DN Solutions for you.

### READILY AVAILABLE - ANYWHERE IN THE WORLD

Machining centres (including 5-axis machines), lathes, multi-tasking turning centres and mill-turn machines, and horizontal borers with best-in-class specifications are all available...ready to install.

### EXPERT SERVICE

Our dedicated, experienced and knowledgeable team is totally committed to improving your productivity, growth and success.

# RESPONDING TO CUSTOMERS **ANYTIME, ANYWHERE**

DN Solutions Global Network

**66** Countries

**140** + Sales networks

**3** Factories

**6** Regional HQs



## CUSTOMER SUPPORT AND SERVICES

**We're there for you whenever you need us.**

We help our customers operate at maximum efficiency by providing them with a range of tried, tested and trusted services - from pre-sales consultancy to post-sales support.



### Field services

- On-site service
- Machine installation and testing
- Scheduled preventive maintenance
- Machine repair service



### Parts supply

- Supplying a wide range of original DN Solutions spare parts
- Parts repair service



### Training

- Programming, machine setup and operation
- Electrical and mechanical maintenance
- Applications engineering



### Technical support

- Supports machining methods and technology
- Responds to technical queries
- Provides technical consultancy



**Head Office**

19F, 10, Tongil-ro,  
Jung-gu Seoul,  
Republic of Korea, 04527  
Tel: +82-2-6972-0370/0350  
Fax: +82-2-6972-0400

**DN Solutions America**

19A Chapin Road,  
Pine Brook New Jersey 07058,  
United States  
Tel: +1-973-618-2500  
Fax: +1-973-618-2501

**DN Solutions Europe**

Emdener Strasse 24,  
D-41540 Dormagen, Germany  
Tel: +49-2133-5067-100  
Fax: +49-2133-5067-111

**DN Solutions India**

No.82, Jakkur Village  
Yelahanka Hobli,  
Bangalore-560064  
Tel: + 91-80-2205-6900  
E-mail:  
[india@dncompany.com](mailto:india@dncompany.com)

**DN Solutions China**

Room 101,201,301,  
Building 39 Xinzhuan Highway  
No.258 Songjiang District  
China Shanghai (201612)  
Tel: +86 21-5445-1155  
Fax: +86 21-6405-1472

**DN Solutions Mexico**

Avenida central 605,  
Parque Logistico,  
San Luis Potosi, 78395, Mexico

**DN Solutions Vietnam**

M.O.R.E building 2F, 40A-40B  
Ut Tich Street, 04 Ward 04,  
District Tan Binh District,  
Ho Chi Minh City, Vietnam  
Tel: +84 28-7304-0163

**Sales inquiry**

[sales@dncompany.com](mailto:sales@dncompany.com)