



LARGE RAM-TYPE VERTICAL TURNING CENTER

# PUMA VTR

**1012F/FM/FC** • **1216/M/F/FM/FC** • **1620/M** • **2025/M**



**DN SOLUTIONS**

# PUMA VTR SERIES

1012F/FM/FC · 1216/M/F/FM/FC · 1620/M · 2025/M

The PUMA VTR Series offers the largest table diameter of Ø1250/1600/2000/2500mm (50.0/63.0/80.0 /98.4 inch) in its class. The machines' stability and high-productivity are complemented by their rigid design and wide-column structure.

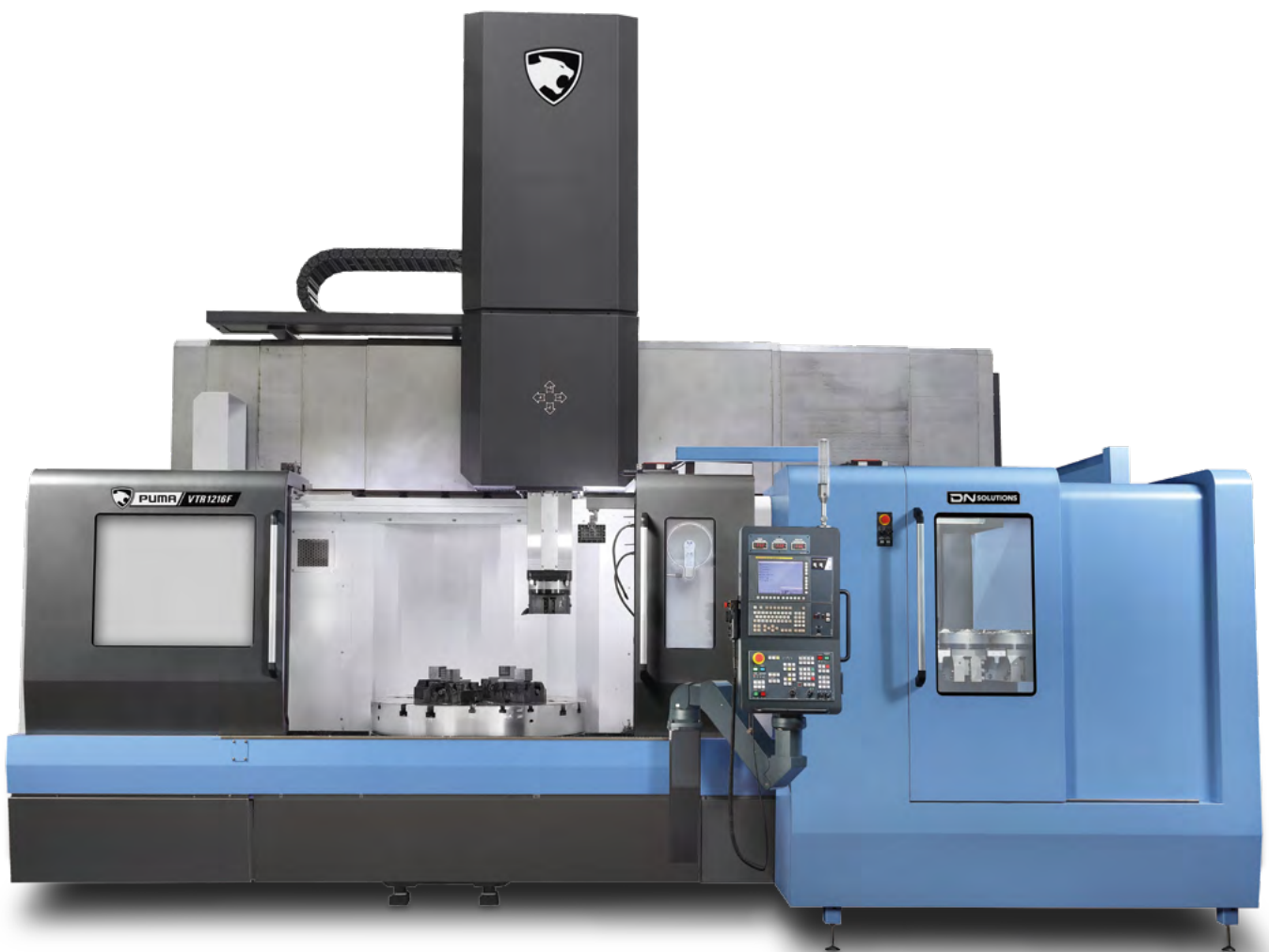

The PUMA VTR Series provides the optimal solution for machining large components made from difficult-to-machine materials - such as aviation engine housings.



### WIDE X-AXIS MOVING & MULTI-ENCLOSED COVER FOR MACHINING FLEXIBILITY

- Full X-axis travel with wide column structure provides a more spacious machining area  
PUMA VTR1012F (-575/+850mm),  
PUMA VTR1216/1216F (-700/+1000mm),  
PUMA VTR1620 (-800/+1420mm),  
PUMA VTR2025(-1000/+1640mm)
- Sealed multi-enclosed cover allows heavy-duty cutting without coolant and chip ingress

### HIGHER PRODUCTIVITY WITH RAM TOOL INDEXING SYSTEM AND ATC (AUTOMATIC TOOL CHANGER)

- 90° RAM indexing with a quad tool holder allows clamping of up to four turning tools and ID/OD/FACE machining without the need for additional tool changes.
- The automatic tool changer (ATC) solution mounting up to 60 tools, can improve productivity and efficiency, especially when machining difficult-to-machine materials like SUS (Stainless), Titanium, Inconel etc.

### IMPROVED PRODUCTIVITY WITH POWERFUL CUTTING CAPABILITIES

- The high-strength Cr-Mo alloy steel RAM provides 8000kgf of tool clamping force, delivering durability and providing excellent heavy-duty machining performance

# BASIC STRUCTURE

The largest machining area in its class guarantees high-productivity and optimised flexibility when machining large workpieces.

## X-axis travel distance

PUMA VTR1012 series

**1425**(-575/+850) mm  
56.1(-22.6/+33.5) inch

PUMA VTR1216 series

**1700**(-700/+1000) mm  
66.9(-27.6/+39.4) inch

PUMA VTR1620 series

**2220**(-800/+1420) mm  
87.4(-31.5/+55.9) inch

PUMA VTR12025/M

**2640**(-1000/+1640) mm  
103.9(-39.4/+64.6) inch

## W-axis travel distance

PUMA VTR1216/M

**500** (250x2Step) mm  
19.7 (9.8x2step) inch

PUMA VTR1620/M

**840** (280x3Step) mm  
33.1 (11.0x2Step) inch

PUMA VTR2025/M

**1020**(340x3Step) mm  
40.2 (13.4x2Step) inch

## Max. loading capacity

PUMA VTR1012 series

**6000** kg 13227.5 lb

PUMA VTR1216 series

**8000** kg 17636.7 lb

PUMA VTR1620 series

**10000** kg 22045.9 lb

PUMA VTR2025 series

**15000** kg 33068.9 lb

## The W-axis can be selected for machining long shafts or for deep pocket machining

Featuring a wide, one-piece type bed and wide column design, and supported by a large capacity cooler, the PUMA VTR Series guarantees long, powerful, and stable machining performance. Depending on workpiece length (height) and shape etc., a cross-rail fixed or movement type (W-axis) configuration is available.

### Cross-rail movement type(W-axis)

PUMA VTR1216/M,  
PUMA VTR1620/M

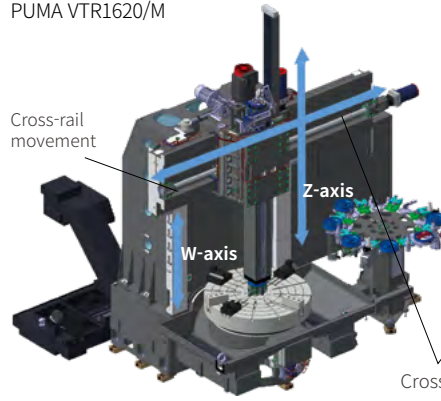

### Cross-rail fixed type

PUMA VTR1012F/FM/FC  
PUMA VTR1216F/FM/FC

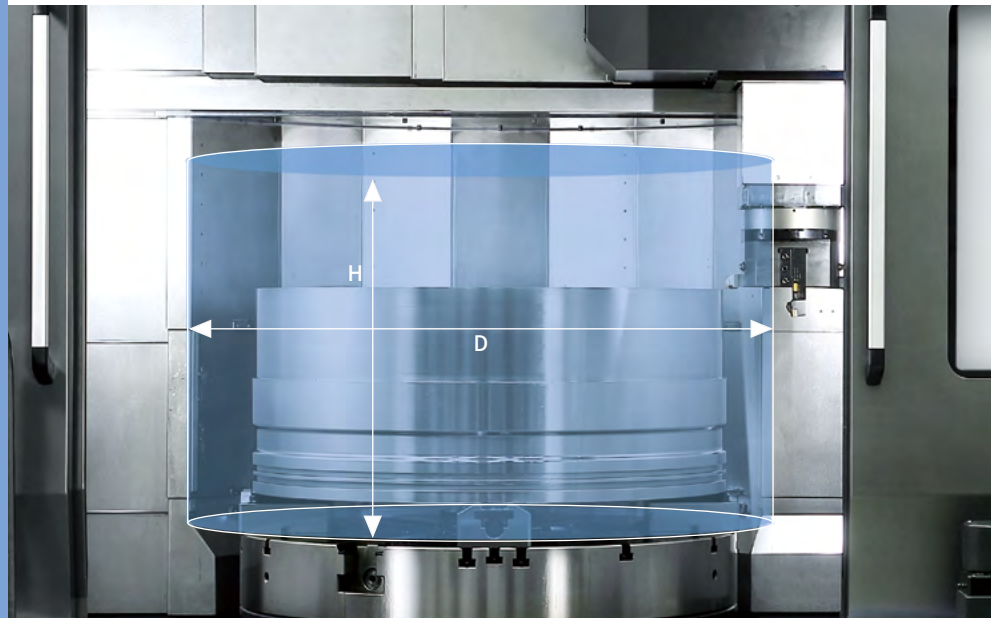
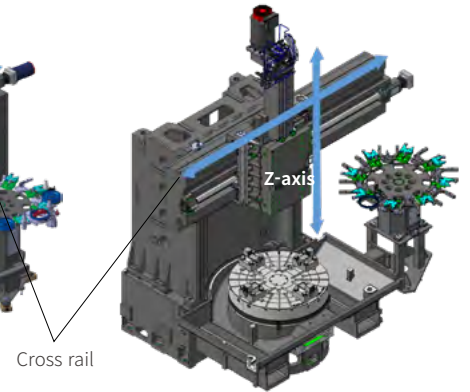

Unit : mm (inch)

Description	PUMA VTR1012F	PUMA VTR1012FC	PUMA VTR1216F	PUMA VTR1216FM	PUMA VTR1216FC	PUMA VTR1216	PUMA VTR1216M	PUMA VTR1620	PUMA VTR1620M	PUMA VTR2025	PUMA VTR2025M
Max. Turning Diameter (D)	1250 (49.2)		1600 (63.0)				2000 (78.7)		2500 (98.4)		
Max. Turning Height (H)	750 (29.5)	695 (27.4)	950 (37.4)	895 (35.2)	1250 (49.2)	1800 (70.9)		2000 (78.7)			

# SPINDLE

## Max. torque

PUMA VTR1012 series

**19217** N·m option  
14182.1 ft-lbs

PUMA VTR1216 series

**31997** N·m option  
23613.8 ft-lbs

PUMA VTR1620 series

**38373** N·m option  
28319.3 ft-lbs

PUMA VTR2025 series

**46720** N·m option  
34479.4 ft-lbs

## Max. power

PUMA VTR1012 series

**70** kW option  
93.9 Hp

PUMA VTR1216/1620/2025 series

**75** kW option  
100.6 Hp

## RAM tool

The servo-driven tool magazine offers fast and accurate tool selection.

## RAM size

**260X260** mm  
10.2 X 10.2 inch

## Tool clamping force

**8** ton  
17637 lb

## Spindle

Supplied with a high-capacity cooler as standard, the thermally-symmetrical spindle delivers reliable, stable and long-term precision machining.



## High productivity RAM indexing

The tool holder's 8 tons of clamping force is ideal for heavy-duty machining operations. DN Solutions's unique ram indexing and quad holder technologies enable the use of 4 tools, with a 90° rotation, without having to use the machine's ATC, thereby increasing overall productivity. The automatic tool changer (ATC) solution mounting up to 60 tools, can also improve productivity and efficiency, especially when machining difficult-to-machine materials like SUS (Stainless), titanium, inconel etc.

### Quad holder option

Up to 4 tools can be used in one set-up



PUMA VTR1012F/FM  
PUMA VTR1216/M/F/FM  
PUMA VTR1620/M  
PUMA VTR2025/M

### CAPTO holder (C6, C8 option)

Automatic exchange of up to 60 tools



PUMA VTR1012FC,  
PUMA VTR1216FC

# ATC TOOL MAGAZINE

The servo-driven ATC tool magazine enables fast and accurate tool selection.

## Max. tool storage capacity

PUMA VTR1012F/1216F/1216/1620/2025

**12, 24** ea option

## Max. tool length

Model	Unit	Vertical	Horizontal**
PUMA VTR1012F/1216F	mm (inch)	500 (19.7)	150 (5.9)
PUMA VTR1216		590 (23.2)	150 (5.9)
PUMA VTR1620/2025		590 (23.2)	200 (7.9)

\*\* length from Ram(except FC models)

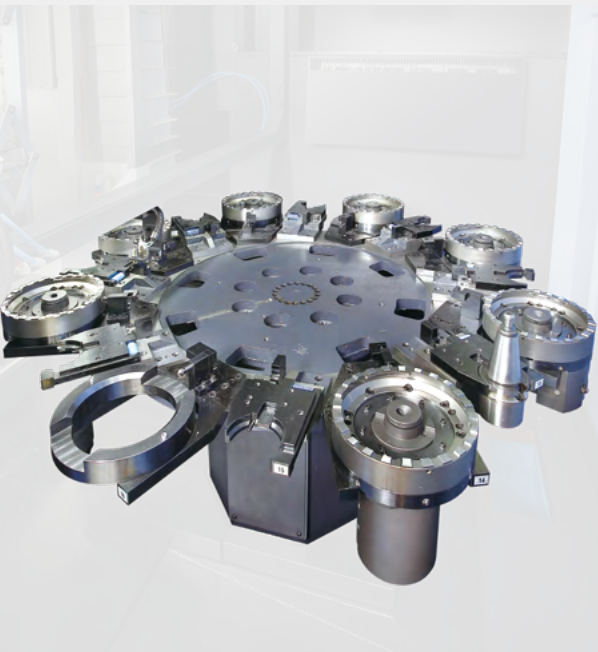
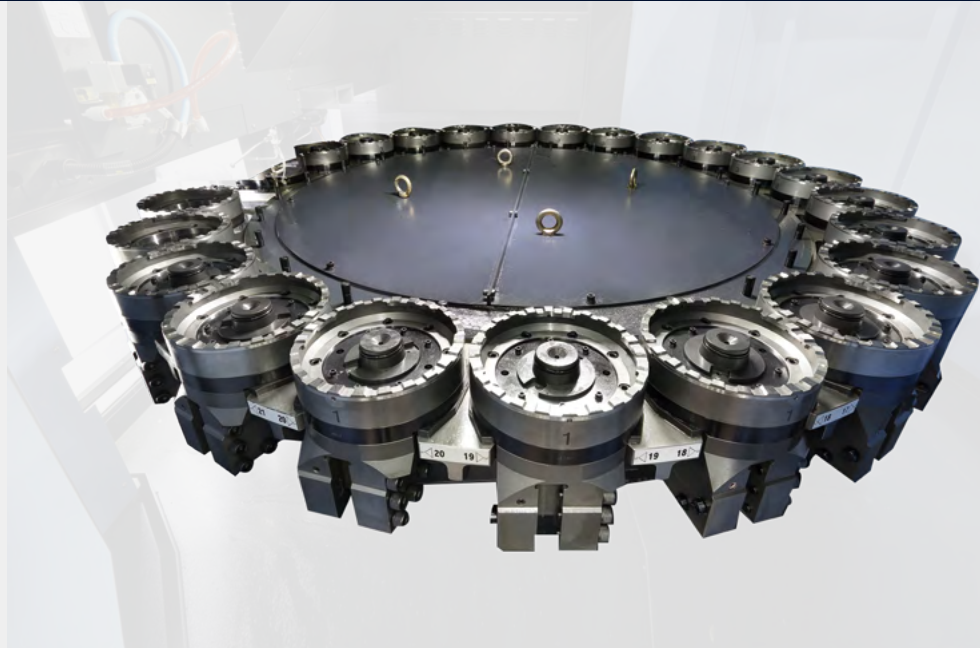

## Max. tool storage capacity

PUMA VTR 1012FM/  
1216FM/1216M/1620M/2025M

**15** ea  
(7 for turning, 8 for milling, 1 for milling cap)

**23** ea option  
(11 for turning, 12 for milling, 1 for milling cap)

**33** ea option  
(12 for turning, 21 for milling, 1 for milling cap)

## Max. tool length

Model	Division	Unit	Vertical	Horizontal**
PUMA VTR1012FM VTR1216FM	Turning	mm (inch)	500 (19.7)	150 (5.9)
	Milling		530 (20.9)	200 (7.9)
PUMA VTR1216M	Turning		590 (23.2)	150 (5.9)
	Milling		650 (25.6)	200 (7.9)
PUMA VTR 1620M/2025M	Turning	590 (23.2)	200 (7.9)	
	Milling	650 (25.6)	200 (7.9)	

\*\* length from Ram(except FC models)

## Max. tool storage capacity

PUMA VTR1012FC/1216FC

**60** ea

(Coromant Capto® C6, C8 option ,  
Horizontal 30ea, Vertical 30ea)



# MULTI-ENCLOSED COVER

## Efficient coolant and chip disposal

The disposal system prevents coolant and chips from blowing out of the machine, and the compact cover design is optimized for loading/unloading workpieces and for machine maintenance.



## Linear scales

Linear scales are included as standard to help maintain high precision.

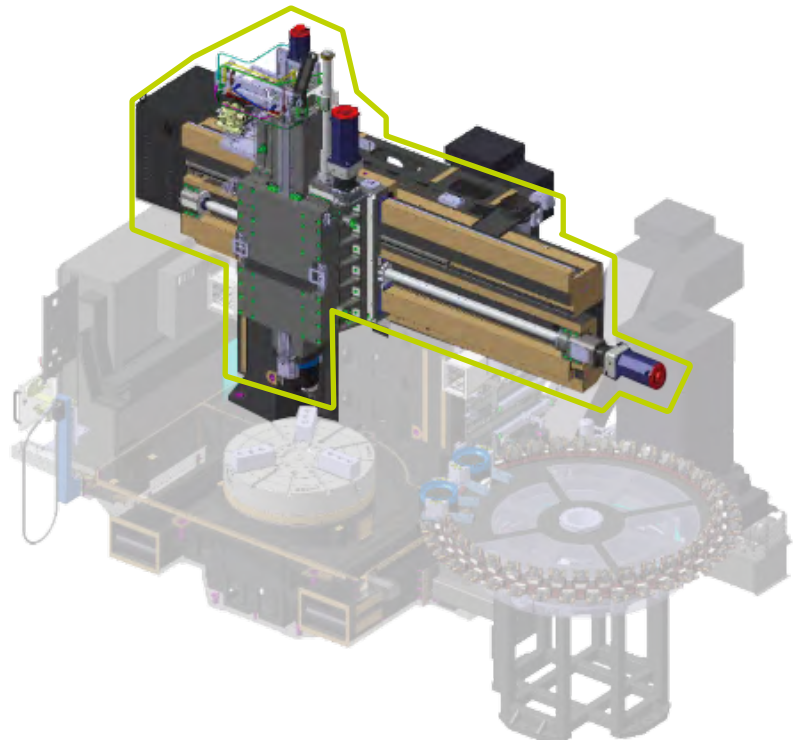

## High accuracy

Linear scales on the X- and Z-axes (cross-rail fixed models) and on the W-axis (cross-rail movement type) are available.

# STANDARD | OPTIONAL SPECIFICATIONS

A range of options is available to suit individual requirements.

Description	Features	PUMA VTR1012F	PUMA VTR1012FC	PUMA VTR1012FM	PUMA VTR1216F	PUMA VTR1216FC	PUMA VTR1216	PUMA VTR 1216M/FM	PUMA VTR1620	PUMA VTR1620M	PUMA VTR2025	PUMA VTR2025M
Main spindle	45/37 kW, 12354 N·m	●	●	●	●	●	●	●	●	●	●	●
	45/37 kW, 20557 N·m	X	X	X	●	●	●	●	X	X	X	X
	45/37 kW, 24668 N·m	X	X	X	X	X	X	X	●	●	X	X
	70/45/37 kW, 19217 N·m	○	○	X	X	X	X	X	X	X	X	X
	70/45/37 kW, 31997 N·m	X	X	○	○	○	○	○	X	X	X	X
	70/45/37 kW, 38373 N·m	X	X	X	X	X	X	X	○	○	X	X
	75/60 kW, 31147 N·m	X	X	○	X	X	X	○	X	X	X	X
	75/60 kW, 37376 N·m	X	X	X	X	X	X	X	X	○	X	X
75/60 Kw, 46720 N·m	X	X	X	X	X	X	X	X	X	●	●	
Chuck	NONE	○	○	○	○	○	○	○	○	○	○	○
	1000 mm_Manual_4-JAW	●	●	●	X	X	X	X	X	X	X	X
	1000 mm_Power 3-JAW	○	○	○	X	X	X	X	X	X	X	X
	1250 mm_Manual 4-JAW	X	X	X	●	●	●	●	X	X	X	X
	1250 mm_Power 3-JAW	X	X	X	○	○	○	○	X	X	X	X
	1250 mm_Combination	X	X	X	○	○	○	○	X	X	X	X
	1400 mm_Manual 4-JAW	X	X	X	○	○	○	○	X	X	X	X
	1400 mm_Power 3-JAW	X	X	X	○	○	○	○	X	X	X	X
	1400 mm_Combination	X	X	X	○	○	○	○	X	X	X	X
	1600 mm_Manual	X	X	X	X	X	X	X	●	●	X	X
	1600 mm_Power 3-JAW	X	X	X	X	X	X	X	○	○	X	X
	1600 mm_Combination	X	X	X	X	X	X	X	○	○	X	X
	1800 mm_Manual 4-JAW	X	X	X	X	X	X	X	○	○	X	X
	1800 mm_Power 3-JAW	X	X	X	X	X	X	X	○	○	X	X
	1800 mm_Combination	X	X	X	X	X	X	X	○	○	X	X
	2000mm_Manual_4-JAW	X	X	X	X	X	X	X	X	X	●	●
	2000mm_Power_3-JAW	X	X	X	X	X	X	X	X	X	○	○
	2000mm_Combination	X	X	X	X	X	X	X	X	X	○	○
2300mm_Manual_4-JAW	X	X	X	X	X	X	X	X	X	○	○	
Soft top jaws	None	●	●	●	●	●	●	●	●	●	●	●
	Manual-4 ea(1 set)	○	○	○	○	○	○	○	○	○	○	○
	Manual-8 ea(2 set)	○	○	○	○	○	○	○	○	○	○	○
	Combination-7 ea(1 set)	X	X	X	○	○	○	○	○	○	○	○
	Combination-14 ea(2 set)	X	X	X	○	○	○	○	○	○	○	○
	Power-3 ea(1 set)	○	○	○	○	○	○	○	○	○	○	○
	Power-6 ea(2 set)	○	○	○	○	○	○	○	○	○	○	○
Hard top jaws	None	●	●	●	●	●	●	●	●	●	●	●
	Manual-4 ea(1 set)	○	○	○	○	○	○	○	○	○	○	○
	Combination-7 ea(1 set)	X	X	X	○	○	○	○	○	○	○	○
	Power-3 ea(1 set)	○	○	○	○	○	○	○	○	○	○	○
Tool shank type	Big Plus BT50	X	X	●	X	X	X	●	X	●	X	●
	Big Plus CAT50	X	X	○	X	X	X	○	X	○	X	○
	Big Plus DIN50	X	X	○	X	X	X	○	X	○	X	○
ATC	12ea	●	X	X	●	X	●	X	●	X	●	X
	24ea	○	X	X	○	X	○	X	○	X	○	X
	60ea(CAPTO C6)	X	●	X	X	●	X	X	X	X	X	X
	60ea(CAPTO C8)	X	○	X	X	○	X	X	X	X	X	X
	15ea(Turning-7ea/Milling-8ea/Milling CAP-1ea)	X	X	●	X	X	●	X	●	X	●	X
	23ea(Turning-11ea/Milling-12ea/Milling CAP-1 ea)	X	X	○	X	X	○	X	○	X	○	X
Coolant pump	33ea(Turning-12ea/Milling-21ea/Milling CAP1 ea)	X	X	○	X	X	○	X	○	X	○	X
	1.1 kW_0.7 Mpa_32 L/min	●	●	●	●	●	●	●	●	●	●	●
	1.1 kW_1.0 Mpa_20 L/min	○	○	○	○	○	○	○	○	○	○	○
	4.0 kW_2.0 Mpa_20 L/min	○	○	○	○	○	○	○	○	○	○	○
	2.9kW_4.0Mpa_33.3L/min	○	○	○	○	○	○	○	○	○	○	○
	7.5 kW_7.0 Mpa_29 L/min	○	○	○	○	○	○	○	○	○	○	○
	15 Mpa (150bar, need tech. discussion in advance)	X	○	X	X	○	X	X	X	X	X	X
Coolant options	High coolant interface	○	○	○	○	○	○	○	○	○	○	○
	Oil Skimmer (Belt type)	○	○	○	○	○	○	○	○	○	○	○
	Coolant flow switch	○	○	○	○	○	○	○	○	○	○	○
	Coolant level switch : Sensing level - low	○	○	○	○	○	○	○	○	○	○	○
Chip disposal options	NONE	●	●	●	●	●	●	●	●	●	●	●
	Rear exit_Hinged belt rear chip conveyor	○	○	○	○	○	○	○	○	○	X	X
	Rear exit_Magnetic scrapper rear chip conveyor	○	○	○	○	○	○	○	○	○	X	X
	Front_Hinged belt rear chip conveyor	X	X	X	X	X	X	X	X	X	○	○
	Front_Magnetic scrapper rear chip conveyor	X	X	X	X	X	X	X	X	X	○	○
	Chip bucket_Forklift 380L	○	○	○	○	○	○	○	○	○	○	○
	Chip bucket_Rotation 380L	○	○	○	○	○	○	○	○	○	○	○
	Chip bucket_Forklift 600L	○	○	○	○	○	○	○	○	○	○	○
	Coolant gun	○	○	○	○	○	○	○	○	○	○	○
Measurement & automation	Automatic workpiece measurement RMP60_RENISHAW	○	○	○	○	○	○	○	○	○	○	○
	Automatic front door and safety devices	○	○	○	○	○	○	○	○	○	○	○
	Tool setter (Auto)	○	○	○	○	○	○	○	○	○	○	○
	ACC (2 station)	○	○	○	○	○	○	○	○	○	X	X
	ACC (Customizing)	Please, contact DN Solutions on further information.										
Accessories	Multi enclosed cover	●	●	●	●	●	●	●	●	●	●	●
	Tool load monitoring system	●	●	●	●	●	●	●	●	●	●	●
	Linear scale (X / Z axis)	●	●	●	●	●	●	●	●	●	●	●
	Auto power off	○	○	○	○	○	○	○	○	○	○	○
	Gravity axis drop prevention	●	●	●	●	●	●	●	●	●	●	●
	Air conditioner	○	○	○	○	○	○	○	○	○	○	○
	Lubricant drop prevention device	○	○	○	○	○	○	○	○	○	○	○
	Installation tool kit	●	●	●	●	●	●	●	●	●	●	●
Maintenance tool kit	○	○	○	○	○	○	○	○	○	○	○	

\* When chuck specification needs to be changed, it may be necessary to replace the chuck cylinder that matches the chuck specification.

● Standard ○ Optional X Not applicable

\* Please contact your DN Solutions representative for detailed machine information.

\* When using a semi-synthetic type or synthetic type, contact our sales representative or service center in advance.

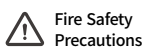

There is a high risk of fire when using non-water-soluble cutting fluids, processing flammable materials, neglecting the controlled and careful use of coolants and modifying the machine without the consent of the manufacturer. Always check the SAFETY GUIDELINES carefully before using the machine.



# PERIPHERAL EQUIPMENT

## Table chuck option

Various types of table chucks are offered, including manual type and hydraulic type.

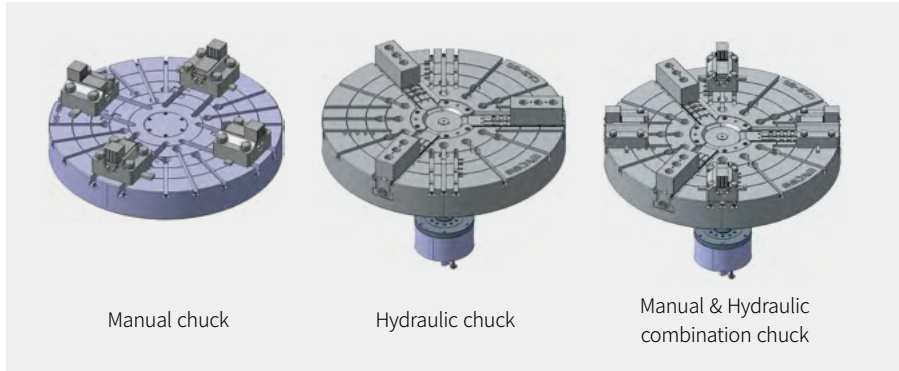

## Internal foot rest

Internal foot rest is available for convenient setting and maintenance.



## Rear exit chip conveyor option

Smooth chip disposal is guaranteed with the one-piece-type bed supplied with chip discharge channels (on both sides of the table), and rear exit dual chip conveyors.

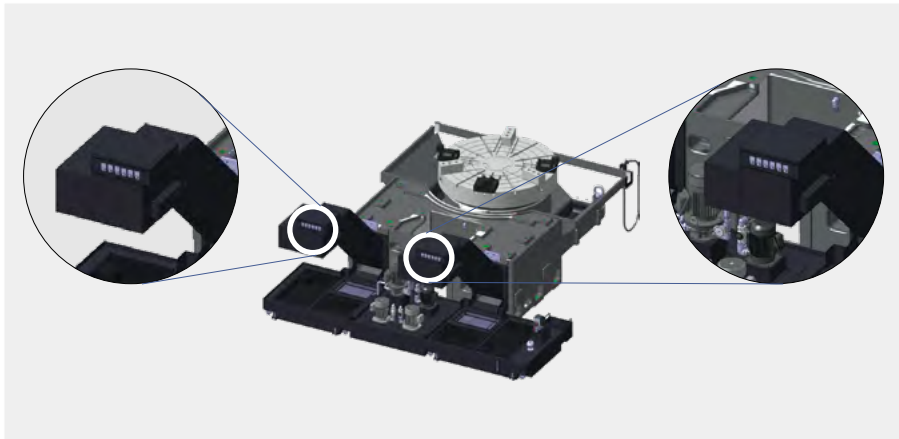

## Automatic tool setter option

The device automatically measures tool length and diameter, detects tool wear and calculates the offset to improve machining accuracy.



## Various tool options option

Tool options include a 90° angle attachment and a grinding unit. The selected tool is driven by the milling spindle motor (M models only).



## 150 bar high pressure TTC

### (Through tool coolant) option

Maintaining low temperatures and ensuring quick and effective chip disposal increase productivity, especially when machining difficult-to-machine materials (PUMA VTR1012FC, 1216FC).



# PERIPHERAL EQUIPMENT

## ACC (Auto Chuck Changer) option (PUMA VTR1012/1216/1620 series)

ACC is auto chuck changer which can save the set-up time and loading/unloading time. Thus it will improve the productivity. There is a sub OP to operate by hand. So you can check where the chuck position is by the screen. It is easy to operate with 10.4" touch-panel that shows the same station position with real machine. (Main unit : Manual chuck 2ea, Set up station & platform, Parking station, Loader station, Spindle receiver unit, Sub OP for ACC)

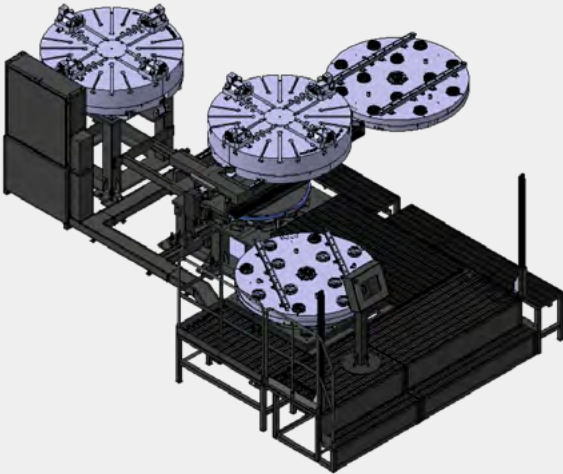

Description	PUMA VTR1012 series	PUMA VTR1216 series	PUMA VTR1620 series
No. of Station	2	2	2
Max. allowance workpiece weight (include chuck)	4500 kg (9920.7 lb)	6000 kg (13227.5 lb)	7000 kg (15432.1 lb)

\* If you want to customize the number of station, please contact DN Solutions.



Operation Panel for ACC with 10" touch screen

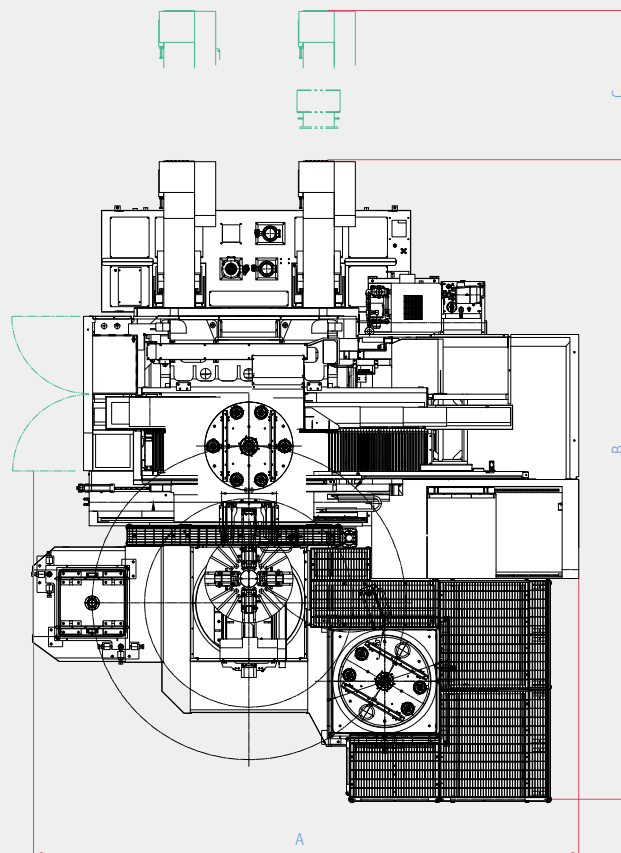

Unit : mm (inch)

Description	A	B	*C
PUMA VTR1012 series	6185 (243.5)	7230 (284.6)	1700 (66.9)
PUMA VTR1216 series	6410 (252.4)	7650 (301.2)	1700 (66.9)
PUMA VTR1620 series	7870 (309.8)	8940 (352.0)	3000 (118.1)

\* C: Space for chip conveyor maintenance

\*\* If you adapt the ACC option the machining range is changed because of height of the special chuck.

# DN SOLUTIONS FANUC i PLUS

DN Solutions Fanuc i Plus maximizes customer productivity and convenience.

## 15" Screen + New OP

DN Solutions Fanuc i Plus' operation panel enhances operating convenience by incorporating common-design buttons and layout. It features a qwerty keyboard for fast and easy data input and operation.

### DN Solutions Fanuc i Plus

- 15-inch color display
- Intuitive and user-friendly design

### USB and PCMCIA card QWERTY keyboard

- EZ-guide i standard
- Ergonomic operator panel
- 2MB memory
- Hot keys



### iHMI touchscreen OPTION

iHMI provides an intuitive interface that uses a touchscreen for quick and easy operation.

### Range of applications

Providing various applications related to planning, machining, improvement and utility, for customer convenience.

### Display

- Crossrail position
- Tool No. display
- Head index No.



- Tool head rotation button



Height adjustable  
369 mm (14.5 inch)

Rotating

The operation panel can be raised, lowered, and swivelled for operating convenience.

## NUMERIC CONTROL SPECIFICATIONS

FANUC

	Description	Features	DN Solutions Fanuc i Plus	
			2-Axis	M
<b>Controlled axis</b>	Controlled axes		2 (X, Z)	3 (X, Z, C)
	Simultaneously controlled axes		2 axes	3 axes
<b>Data input/output</b>	data server		○	○
	Memory card input/output		●	●
	USB memory input/output		●	●
<b>Interface function</b>	Embedded ethernet		●	●
	Fast ethernet		○	○
<b>Operation</b>	Enhanced embedded ethernet function		●	●
	DNC operation	Included in RS232C interface.	●	●
<b>Program input</b>	DNC operation with memory card		●	●
	Workpiece coordinate system	G52 - G59	●	●
<b>Feed function</b>	AI contour control I	G5.1 Q, 40 Blocks	●	●
	AI contour control II	G5.1 Q, 200 Blocks	○	○
<b>Operation guidance function</b>	EZ Guidei (Conversational programming solution)		●	●
	iHMI with machining cycle	Note *1) Only with 15" touch LCD standard	○ *1)	○ *1)
	Multi path function	Supporting 2 or 3 path machine	●	●
	EZ Operation package		●	●
<b>Setting and display</b>	CNC screen dual display function		●	●
<b>Network</b>	FANUC MTConnect		⊕	⊕
	FANUC OPC UA		⊕	⊕
<b>Others</b>	Display unit	15" color LCD	●	●
		15" color LCD with touch panel	○	○
	Part program storage size & Number of registerable programs	5120M(2MB)_1000 programs	●	●
	Dual position feedback		X	●
	Pitch error compensation		●	●

# DN SOLUTIONS FANUC i PLUS

## EZ-Guide i

Using the DN Solutions EZ-Guide i, users can create a cutting program for any desired shape, including patterns, by entering just the dimensions.

Example programming : Cutting shape

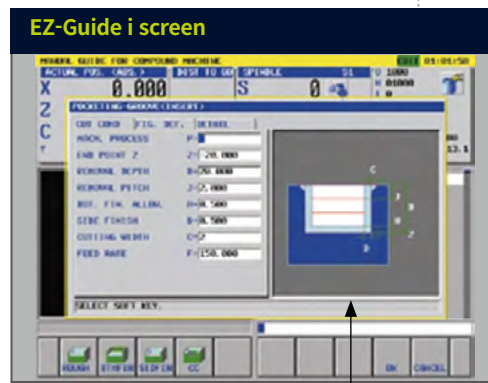
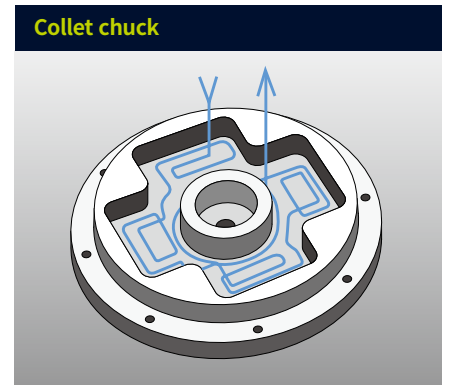
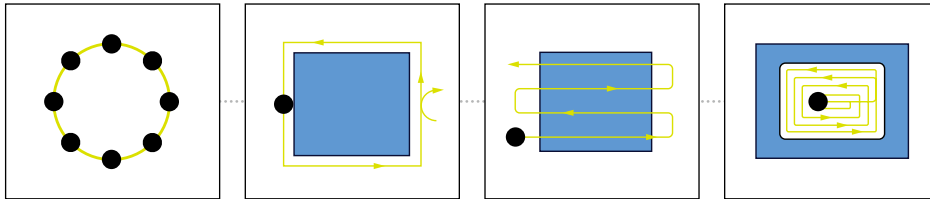

Enter the dimensions of the shape.

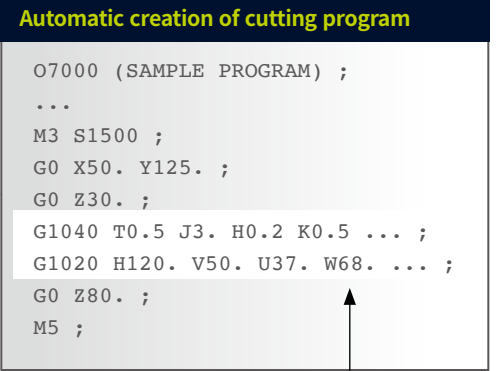

A cutting program is automatically created with the entered values.

## EZ WORK

DN Solutions's unique EZ WORK offers tool management function, peripheral device settings, operation, online help, and other functionalities to maximize operational efficiency and user convenience.

### Tool Load Monitoring

- Detection function to prevent before tool wear and tool breakage
- Set up and show each tool's load



### ATC position compensation

- Tool position change and offset are displayed and set up.
- Easy compensation and prevention against deformation/displacement by long-term operation, etc.



### Thermal error compensation (M-series)

- Improved accuracy with thermal displacement compensation
- Real-time-based machine temperature monitoring



# POWER | TORQUE

## Milling spindle

**PUMA VTR1012FM**  
**PUMA VTR1216M/1216FM**  
**PUMA VTR1620M**

Max speed of live tool

**3000** r/min

Max power of live tool

**18.5** kW

24.8 Hp

Max. torque

**674** N·m

497.4 ft-lbs

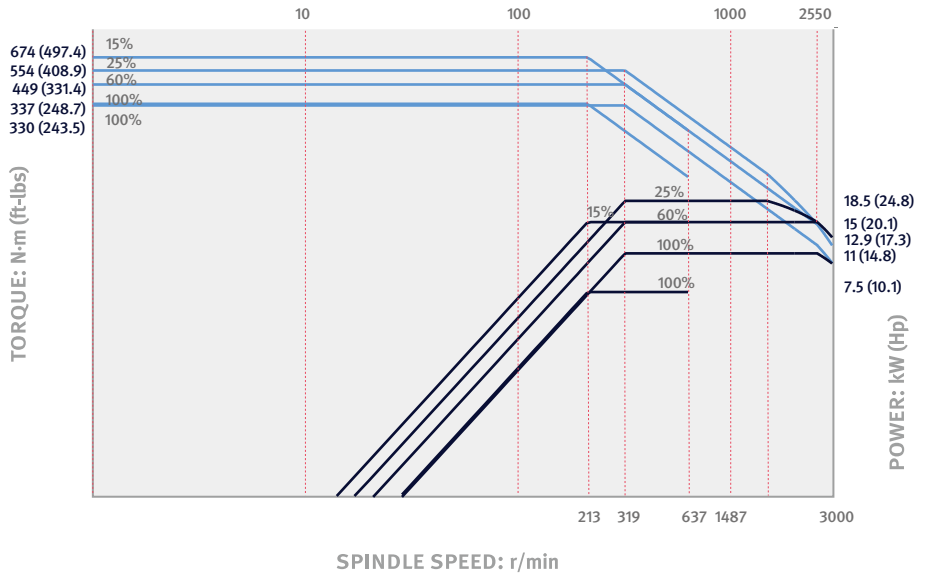

**PUMA VTR1216M/1216FM**

Gearbox option

Max speed of live tool

**3000** r/min

Max power of live tool

**25** kW

33.5 Hp

Max. torque

**1273** N·m

939.5 ft-lbs

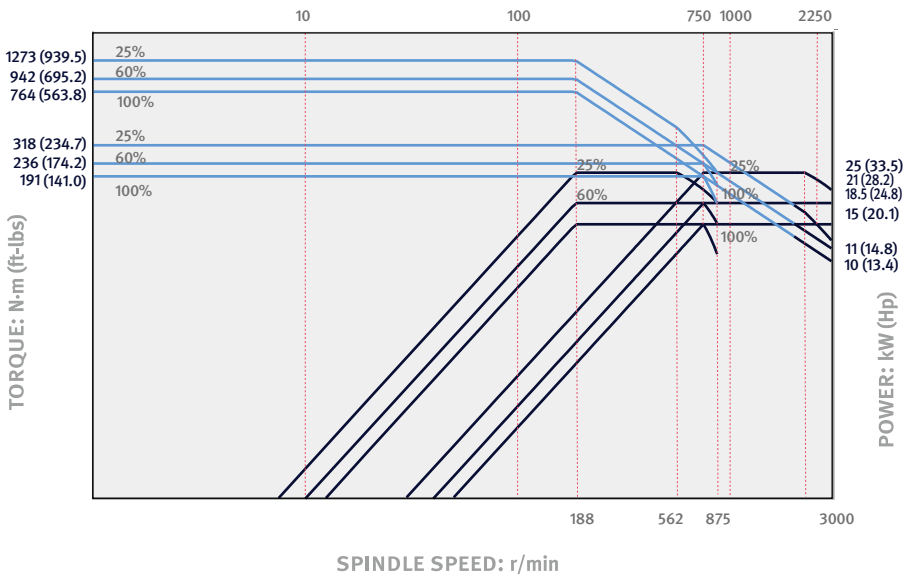

**PUMA VTR1620M /2025M**

Gearbox option

Max speed of live tool

**3000** r/min

Max power of live tool

**35** kW

46.9 Hp

Max. torque

**1782** N·m

1315.1 ft-lbs

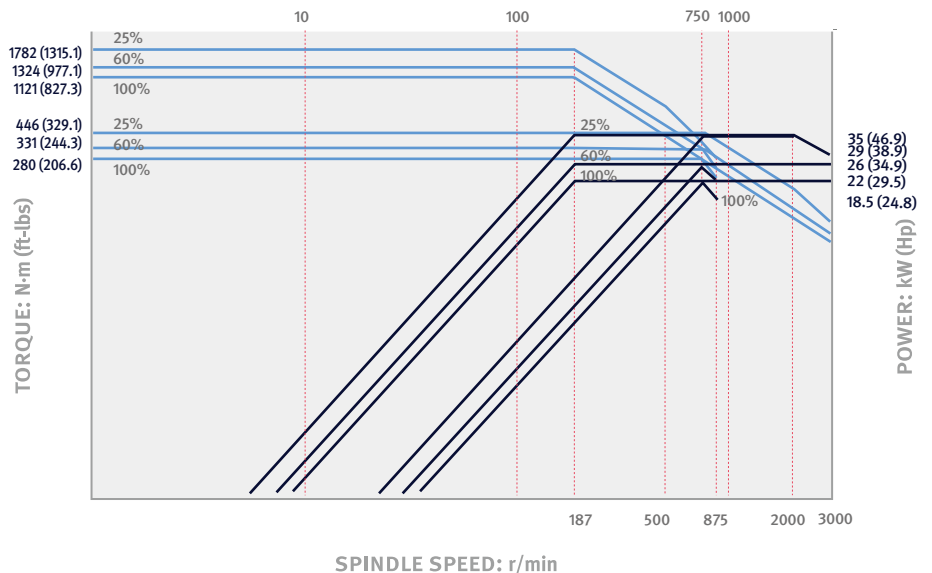

# POWER | TORQUE

## Main Spindle

### PUMA VTR1012F/FC/FM

Max. speed  
**600** r/min

Max. power  
**45** kW  
60.3 Hp

Max. torque  
**12354** N·m  
9117.3 ft-lbs

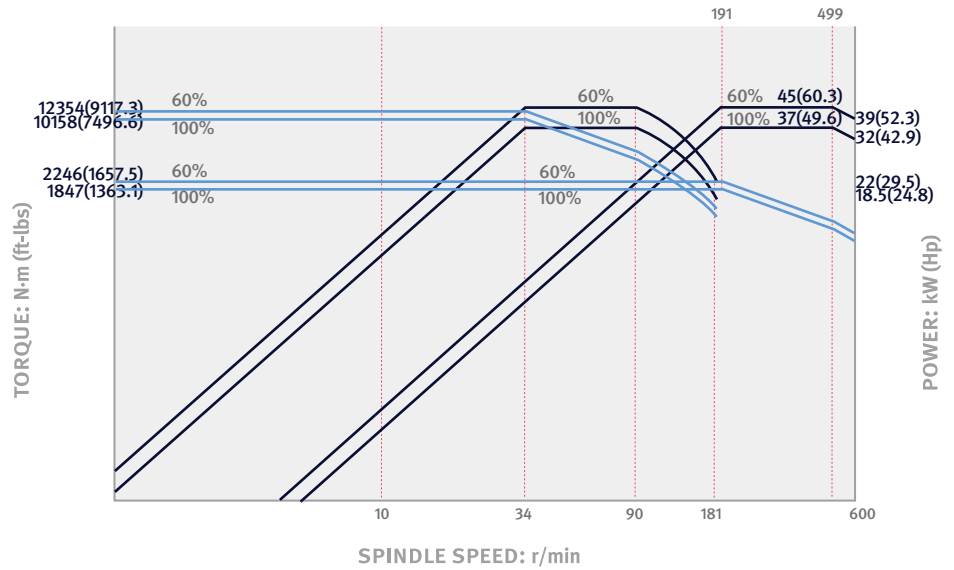

### PUMA VTR1012F/FC/FM

선택

Max. speed  
**600** r/min

Max. power  
**70** kW  
93.9 Hp

Max. torque  
**19217** N·m  
14182.1 ft-lbs

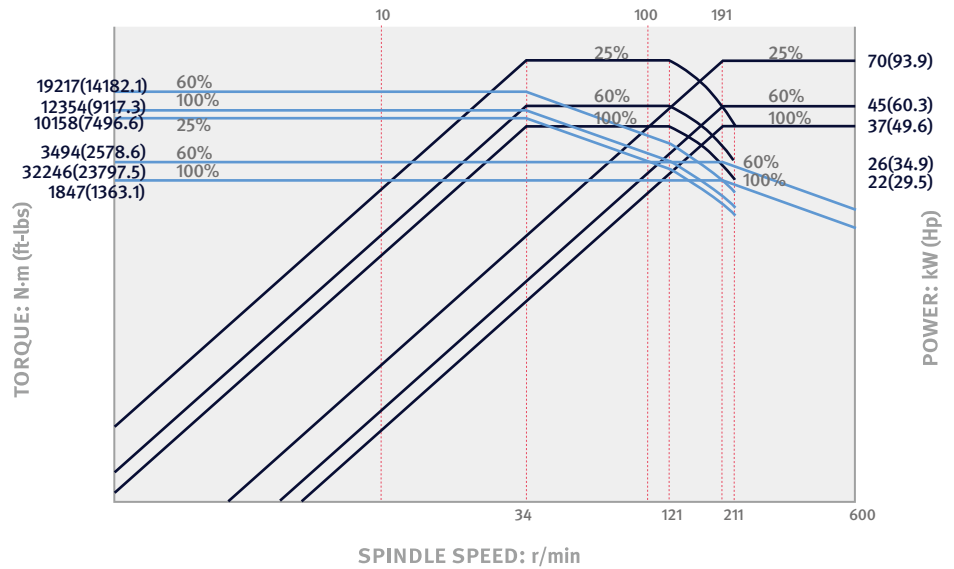

### PUMA VTR2025/M

Max. speed  
**200** r/min

Max. power  
**75** kW  
100.6 Hp

Max. torque  
**46720** N·m  
34479.4 ft-lbs

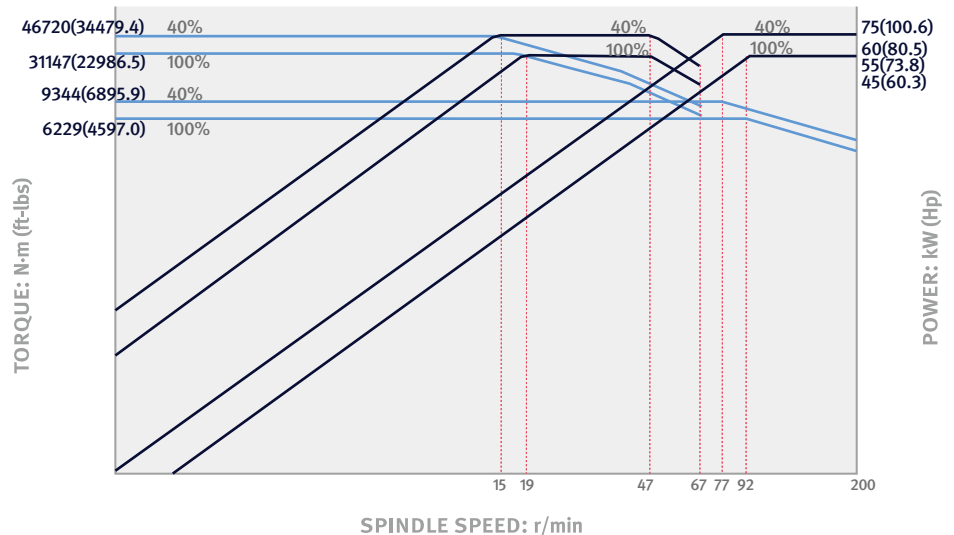

# POWER | TORQUE

## Main Spindle

**PUMA VTR1012FM**  
**PUMA VTR1216M/1216FM**  
**PUMA VTR1620M**

Max. speed  
**400** r/min

Max. power  
**45** kW  
 60.3 Hp

Max. torque  
**20557** N·m  
 15171.1 ft-lbs

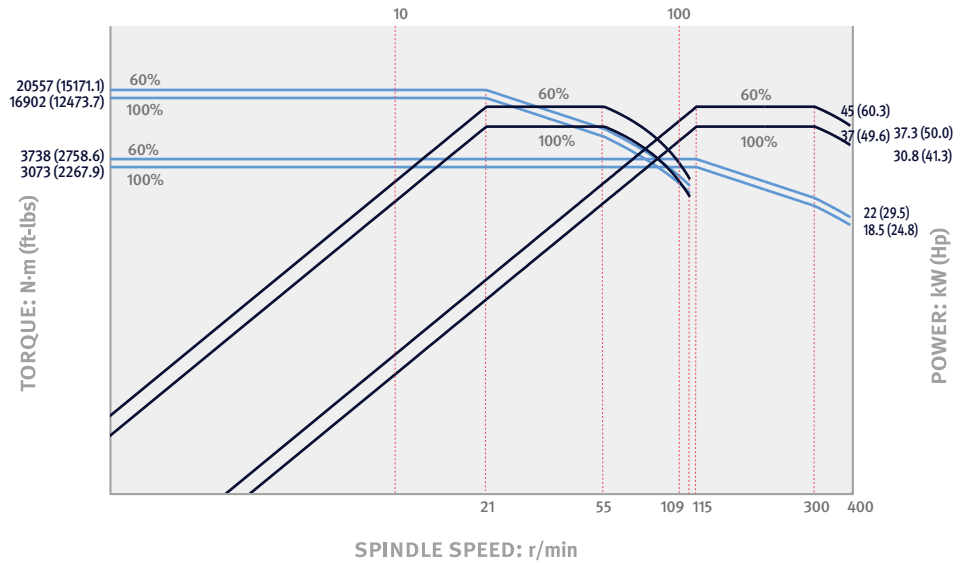

**PUMA VTR1216/M/F** option  
**PUMA VTR1216FM/FC** option

Max. speed  
**400** r/min

Max. power  
**70** kW  
 93.9 Hp

Max. torque  
**31977** N·m  
 23599.0 ft-lbs

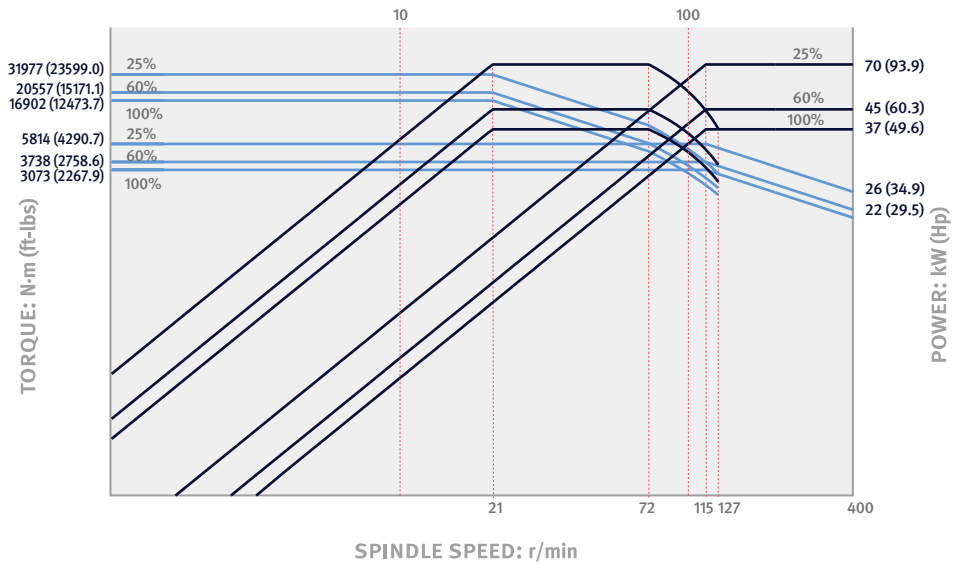

**PUMA VTR1216/M/F** option  
**PUMA VTR1216FM/FC** option

Max. speed  
**400** r/min

Max. power  
**75** kW  
 100.6 Hp

Max. torque  
**31147** N·m  
 22986.5 ft-lbs

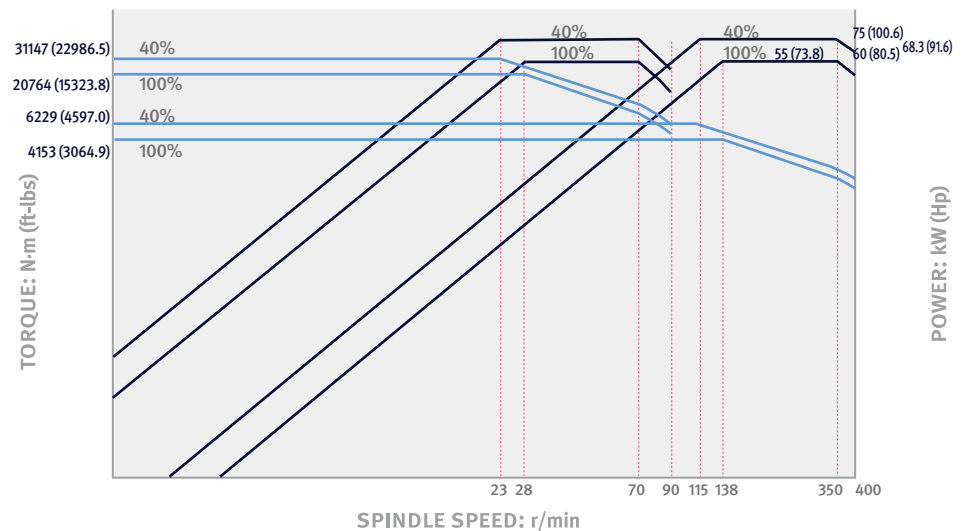

# POWER | TORQUE

## Main Spindle

### PUMA VTR1620/M

Max. speed  
**300** r/min

Max. power  
**45** kW  
60.3 Hp

Max. torque  
**24668** N·m  
18205.0 ft-lbs

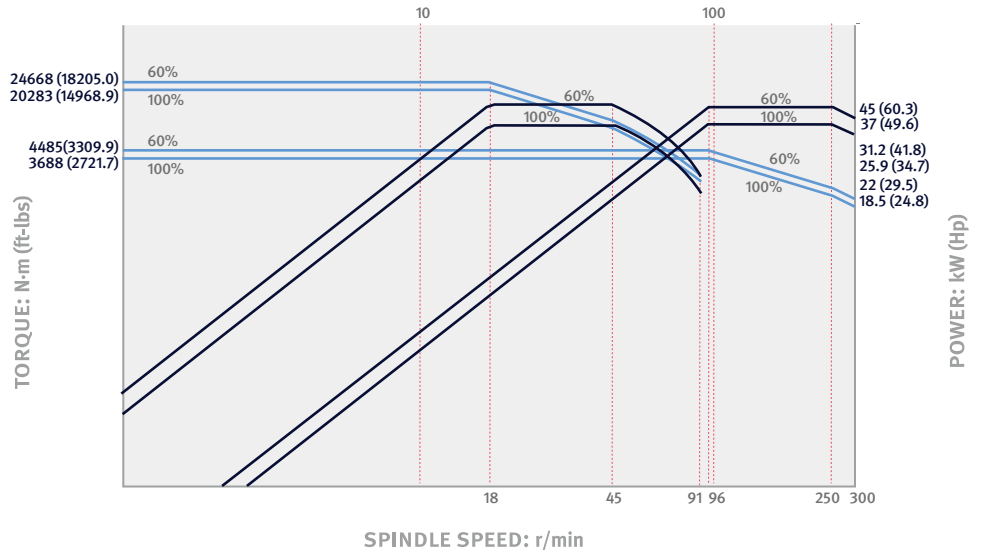

### PUMA VTR1620/M option

Max. speed  
**300** r/min

Max. power  
**70** kW  
93.9 Hp

Max. torque  
**38373** N·m  
28319.3 ft-lbs

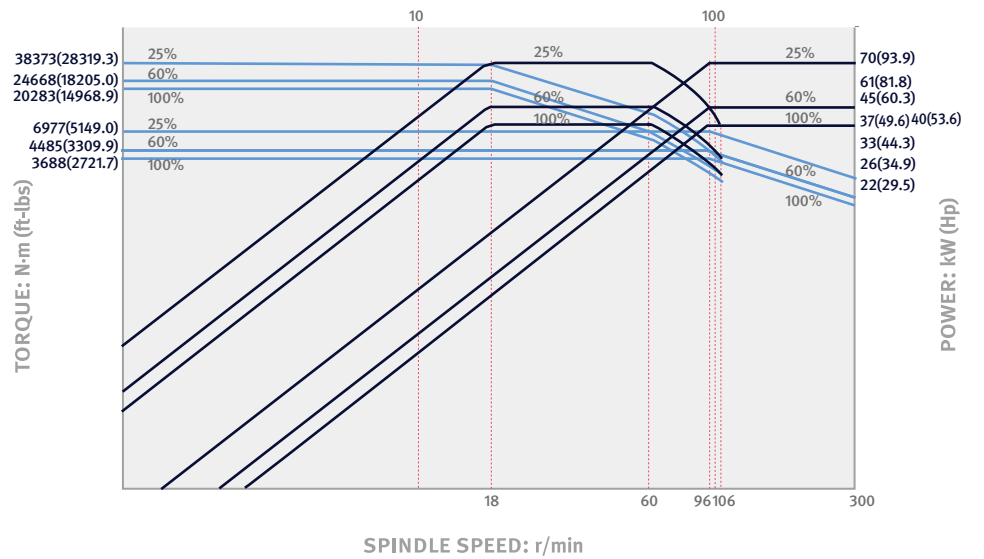

### PUMA VTR1620M option

Max. speed  
**300** r/min

Max. power  
**75** kW  
100.6 Hp

Max. torque  
**37376** N·m  
27583.5 ft-lbs

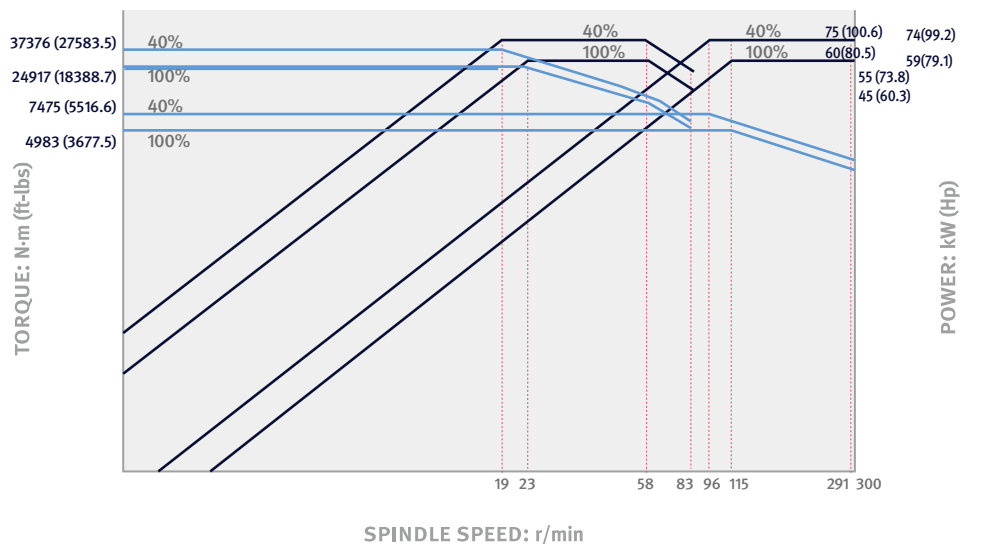



# EXTERNAL DIMENSIONS

**PUMA VTR** 1012/1216/1620 series

Unit : mm (inch)

TOP

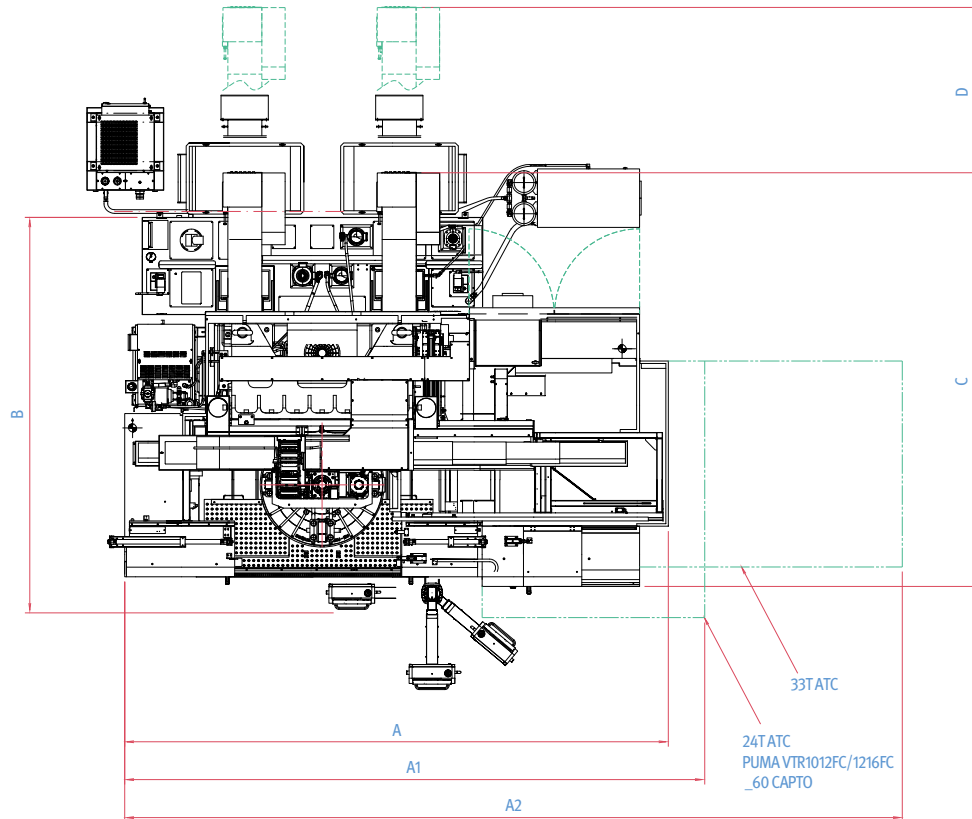

FRONT

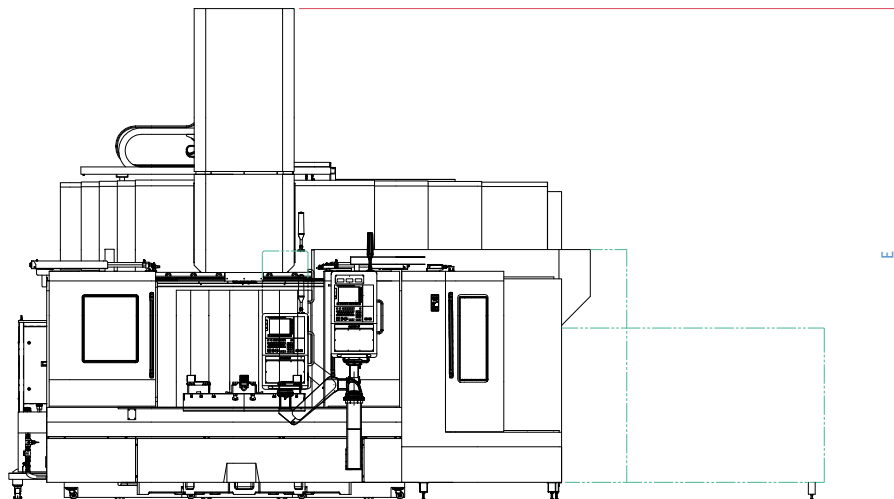

※ Please comply with our company's installation guideline, such as ground condition and anchoring, in order to achieve the maximum precision and performance of the machine.

Description	A	A1 (24ATC)	A2 (33ATC)	B	C	D	E
PUMA VTR1012F/FM	4970 (195.7)	5545 (218.3)	-	3870 (152.4)	4128 (162.5)	1700 (66.9)	4768 (187.7)
PUMA VTR1012FC	4970 (195.7)	5545 (218.3) (60T Capto)	-	3987 (157.0)	4128 (162.5)	1700 (66.9)	4768 (187.7)
PUMA VTR1216F / FM	5590 (220.1)	5965 (219.1)	7995 (314.8)	4066 (160.1)	4225 (166.3)	1700 (66.9)	5065 (199.4)
PUMA VTR1216FC	5590 (220.1)	5965 (219.1) (60T Capto)	-	4115 (162.0)	4225 (166.3)	1700 (66.9)	5065 (199.4)
PUMA VTR1216 / M	5590 (220.1)	5965 (219.1)	7995 (314.8)	4066 (160.1)	4225 (166.3)	1700 (66.9)	5650 (222.4)
PUMA VTR1620 / M	6500 (255.9)	6955 (273.8)	9005 (354.5)	4757 (187.3)	5240 (206.3)	3000 (118.1)	6345 (249.8)

\* Some peripheral equipment can be placed in other places

# EXTERNAL DIMENSIONS

PUMA VTR 2025/M

Unit : mm (inch)

TOP

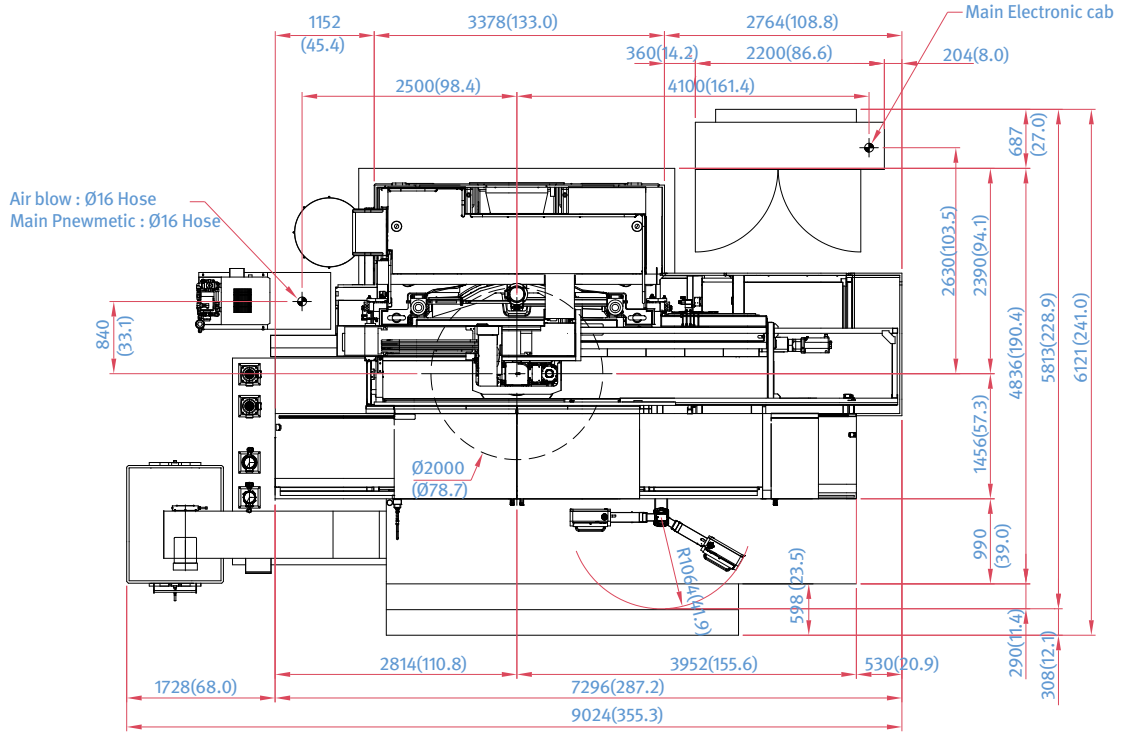

FRONT

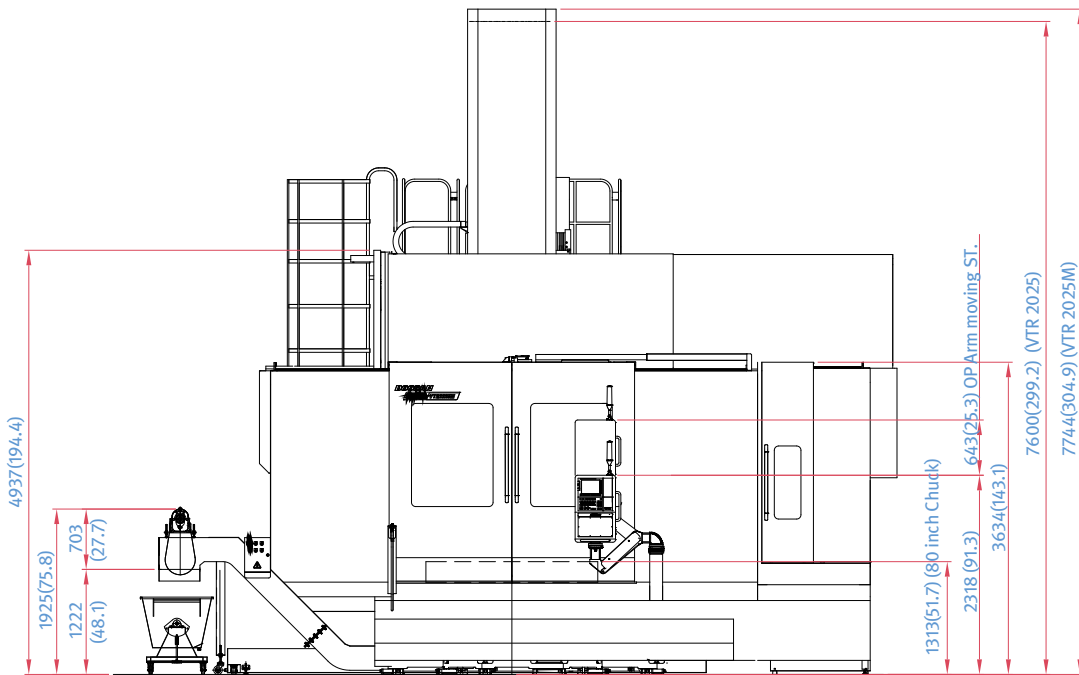

# TOOLING SYSTEM

## Turning

Unit : mm (inch)

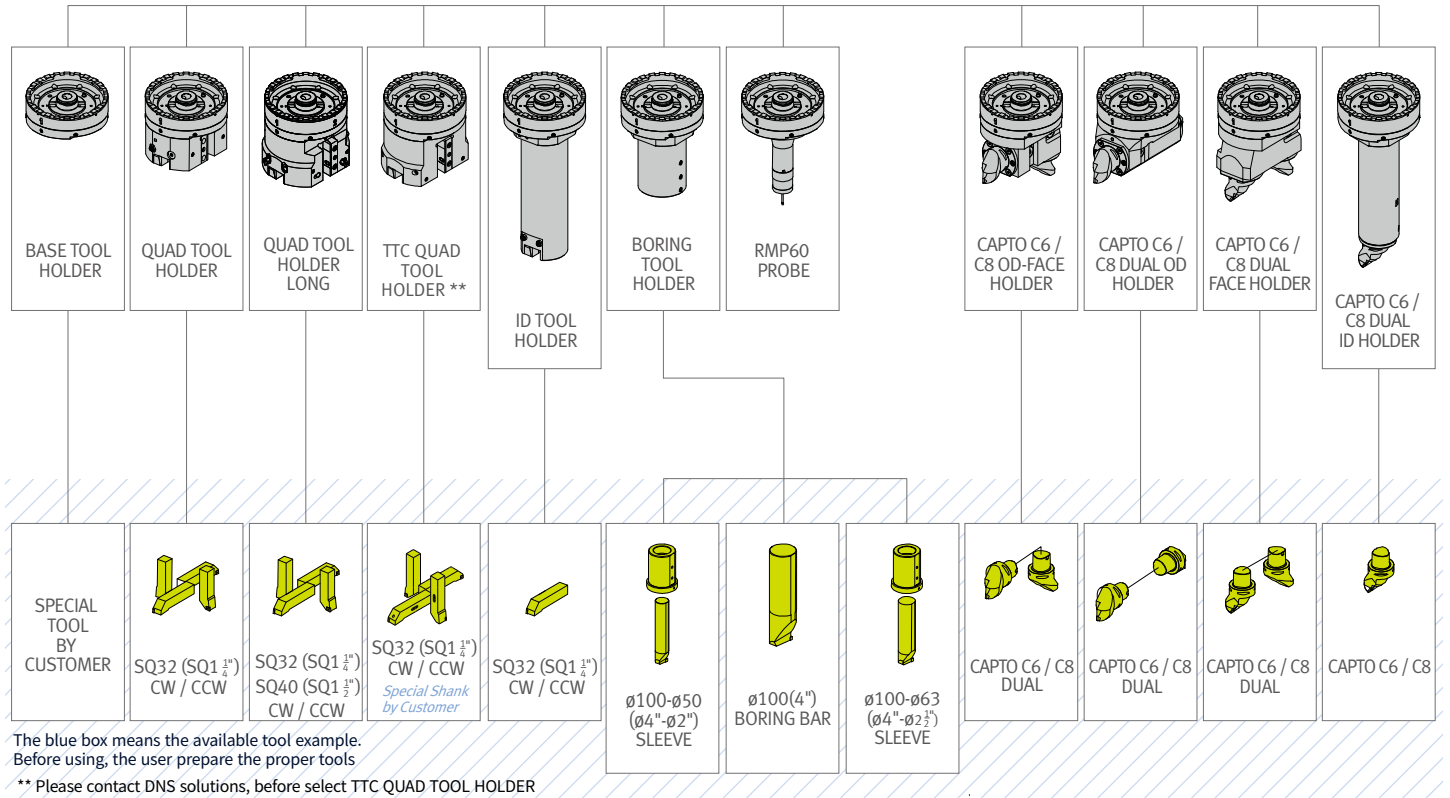

\* PUMA VTR1012FC/VTR1216FC except

## Turning

PUMA VTR1012FC, VTR1216FC

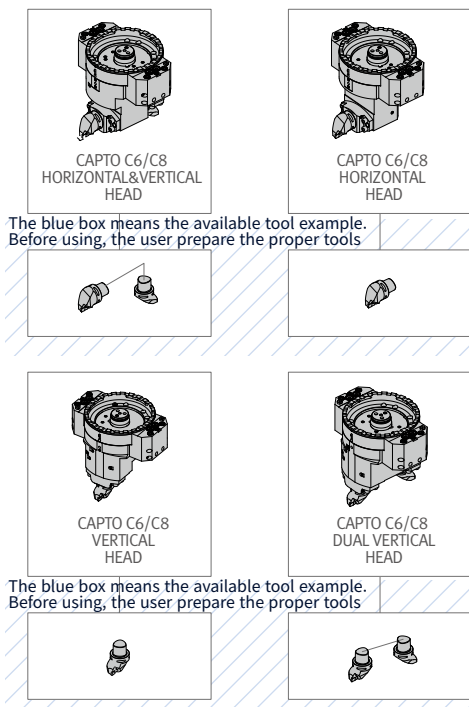

\* HORIZONTAL&VERTICAL HEAD 1set : Standard

## Milling

PUMA VTR1216M/FM, VTR1620M, VTR2025M

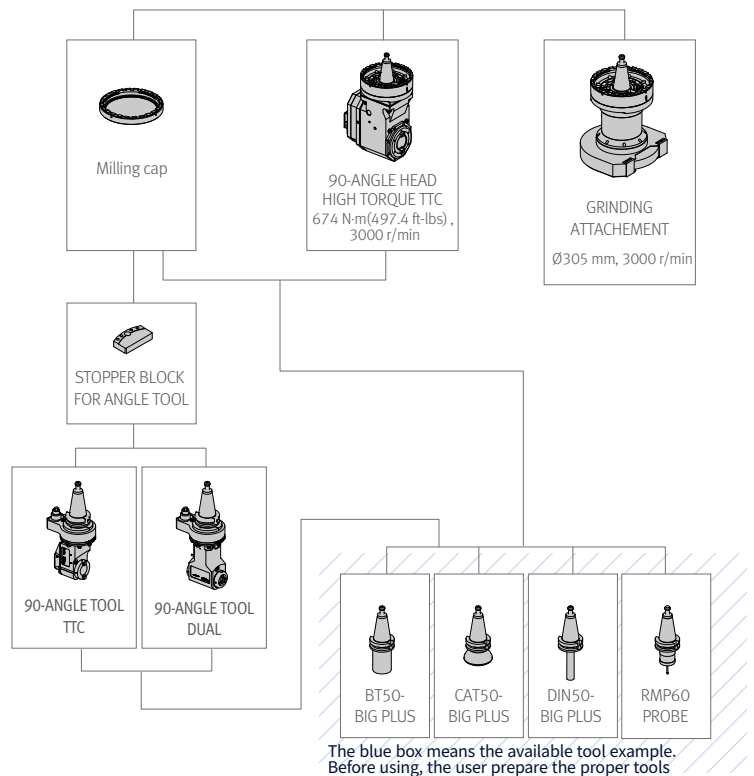

# TOOLING ATTACHMENT

## PUMA VTR Series

Unit : mm (inch)

### BASE TOOL HOLDER option

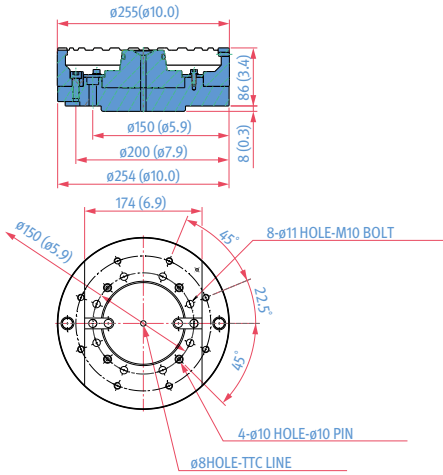

### ID TOOL HOLDER option

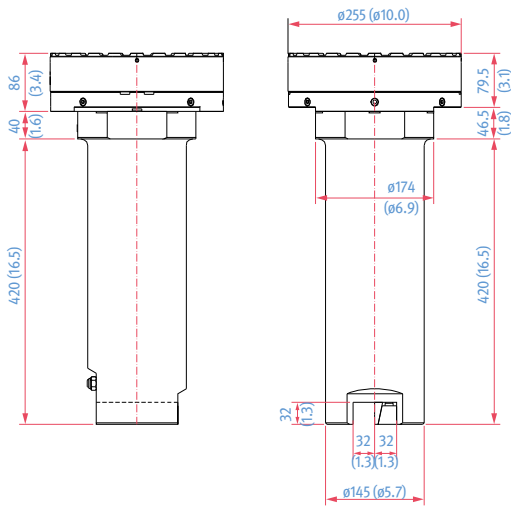

### BORING TOOL HOLDER option

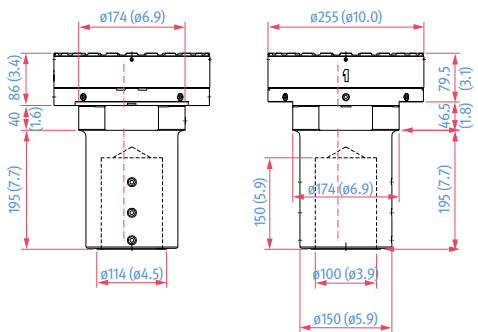

### QUAD TOOL HOLDER option

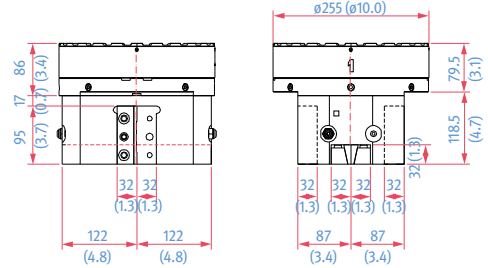

### QUAD TOOL HOLDER\_LONG option

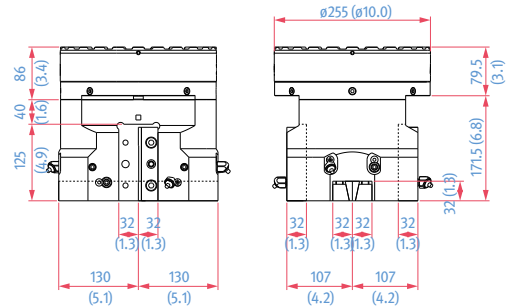

### QUAD TOOL HOLDER(TTC) option

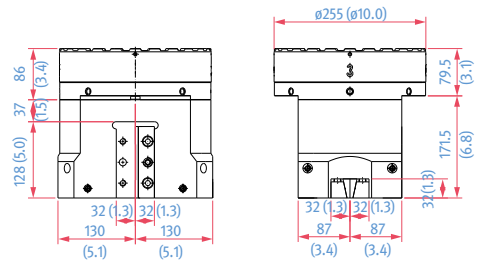

\* Before select TTC QUAD TOOL HOLDE, please contact DN Solutions.

### RMP60 PROBE option

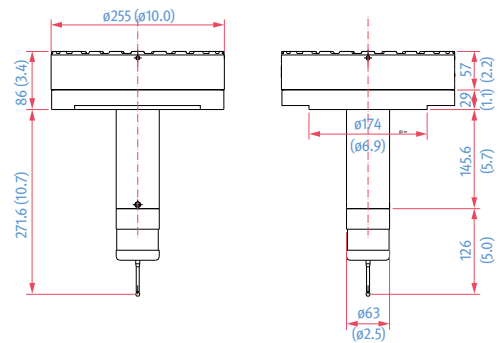

# TOOLING ATTACHMENT

## PUMA VTR Series

Unit : mm (inch)

CAPTO-C6 OD-FACE HOLDER option

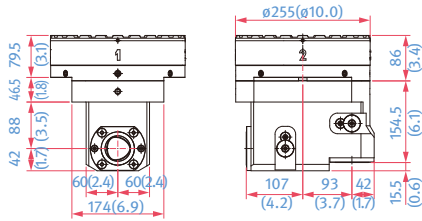

CAPTO-C6 DUAL FACE HOLDER option

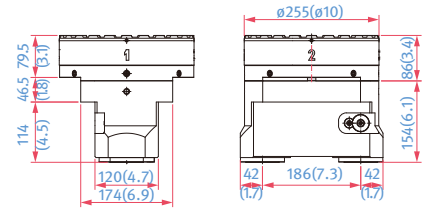

CAPTO-C6 DUAL OD HOLDER option

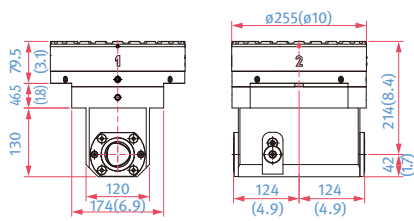

CAPTO-C6 ID HOLDER option

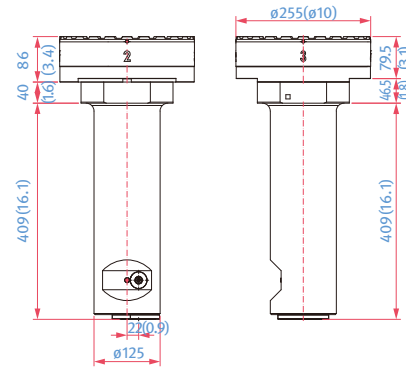

CAPTO-C8 OD-FACE HOLDER option

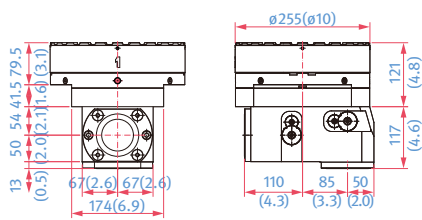

CAPTO-C8 DUAL FACE HOLDER option

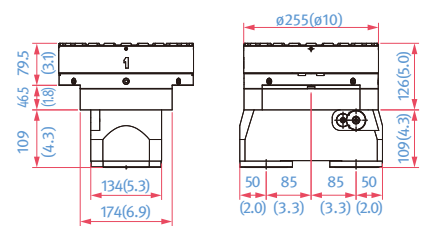

CAPTO-C8 DUAL OD HOLDER option

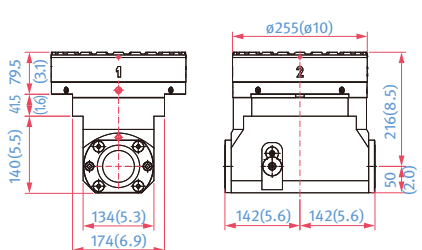

CAPTO-C8 ID HOLDER option

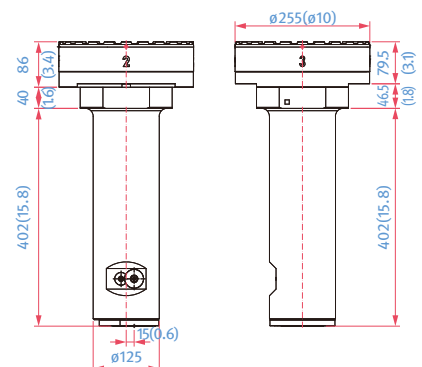

# TOOLING ATTACHMENT

## PUMA VTR Series

Unit : mm (inch)

### 90-ANGLE TOOL TTC option

### 90-ANGLE TOOL DUAL option

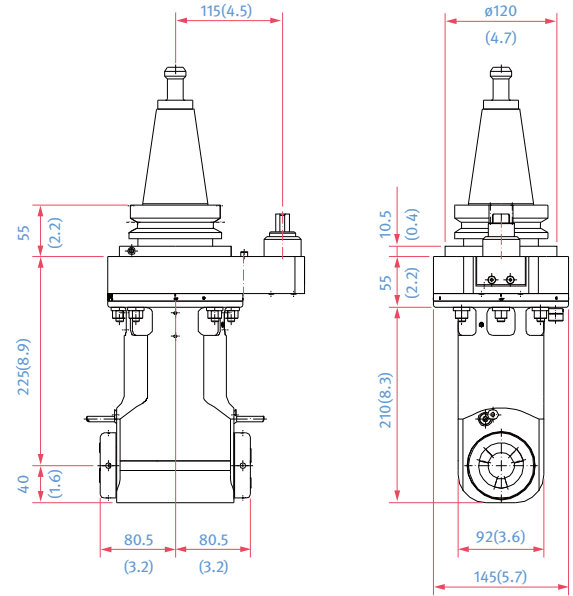
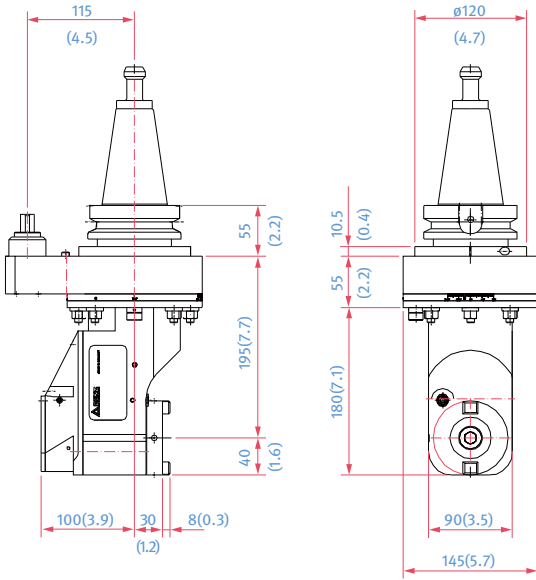

### 90-ANGLE HIGH TORQUE TTC option

### GRINDING ATTACHMENT option

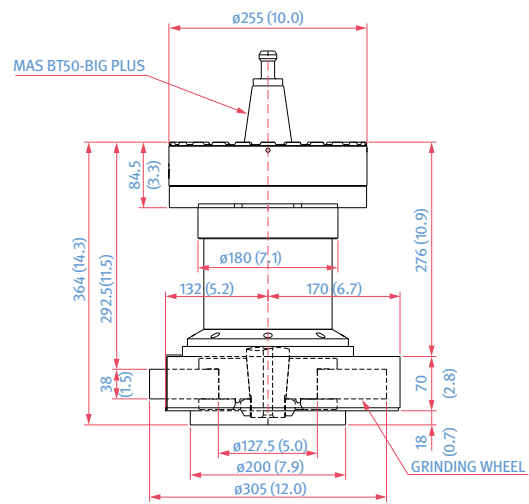
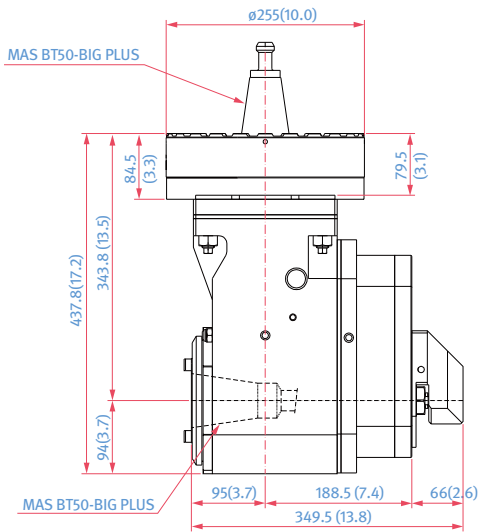

# TOOLING ATTACHMENT

## PUMA VTR1012FC/1216FC

Unit : mm (inch)

CAPTO C6 HORIZONTAL VERTICAL HOLDER **option**

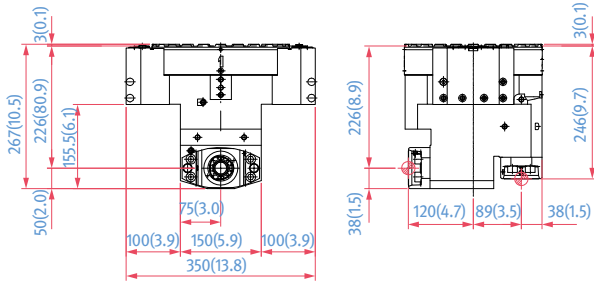

CAPTO C6 HORIZONTAL HOLDER **option**

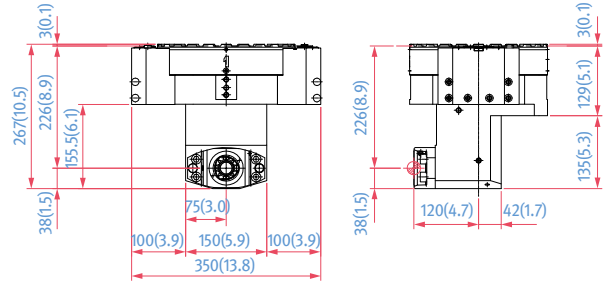

CAPTO C6 VERTICAL HOLDER **option**

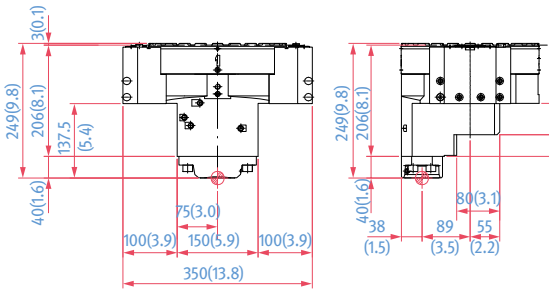

CAPTO C6 DUAL VERTICAL HOLDER **option**

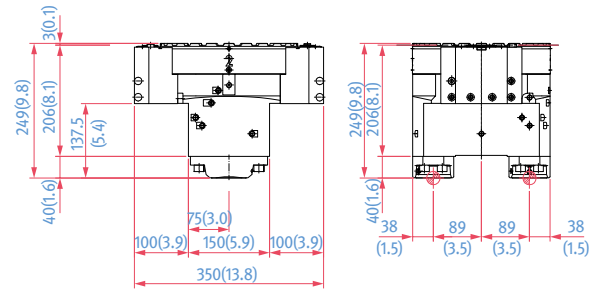

CAPTO C8 HORIZONTAL VERTICAL HOLDER **option**

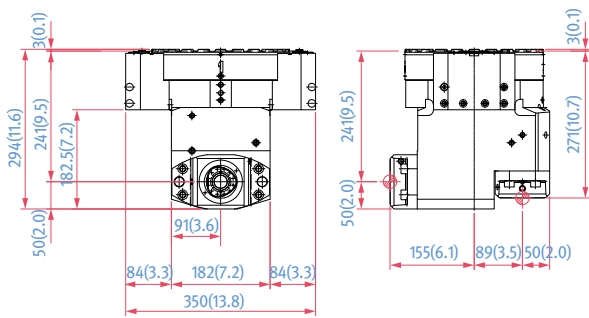

CAPTO C8 HORIZONTAL HOLDER **option**

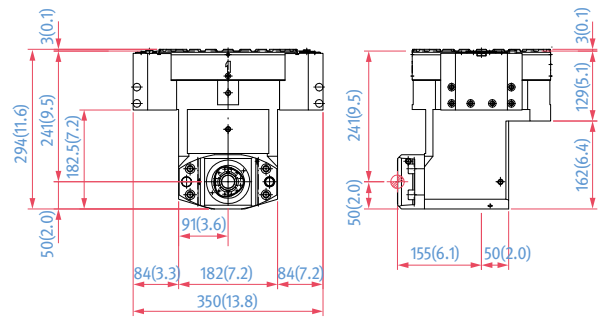

CAPTO C8 VERTICAL HOLDER **option**

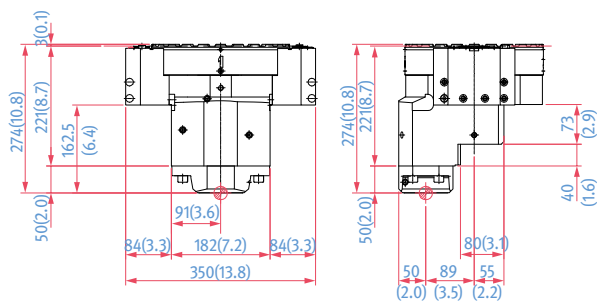

CAPTO C8 DUAL VERTICAL HOLDER **option**

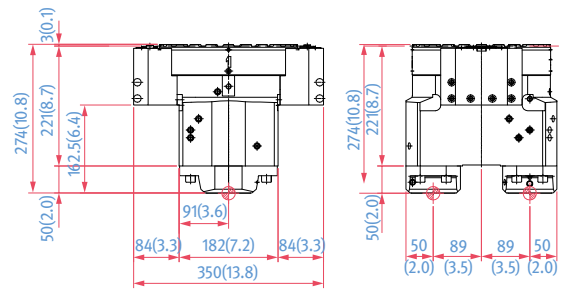

# WORKING RANGE DIAGRAM

## PUMA VTR1012FC

## PUMA VTR1216FC

Unit : mm (inch)

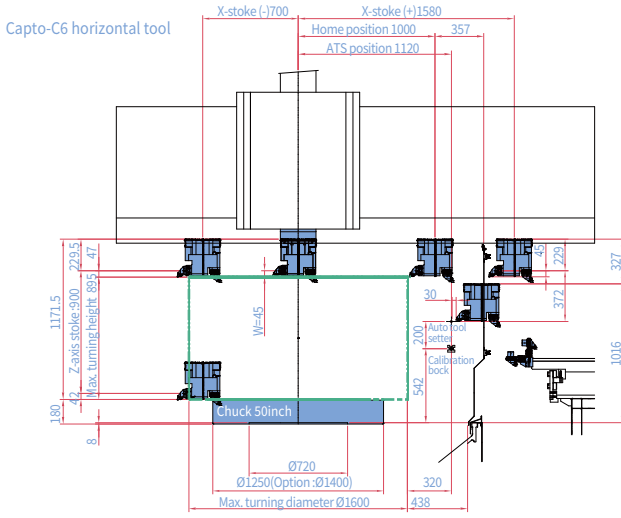
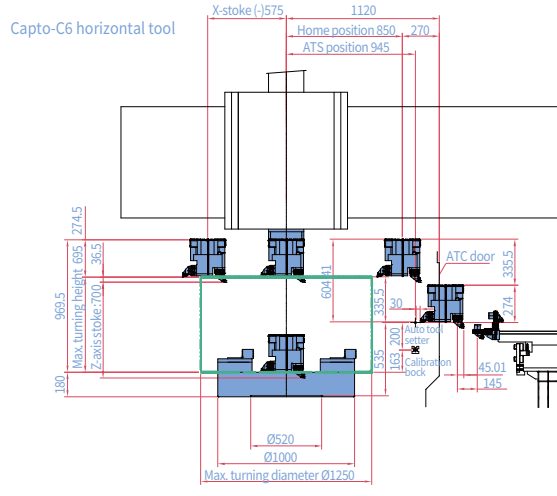
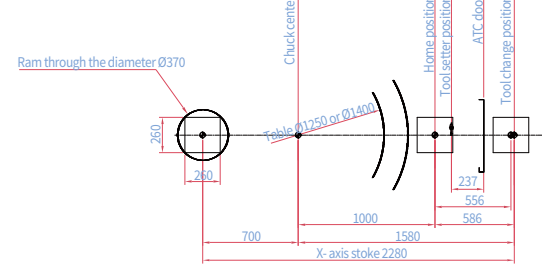
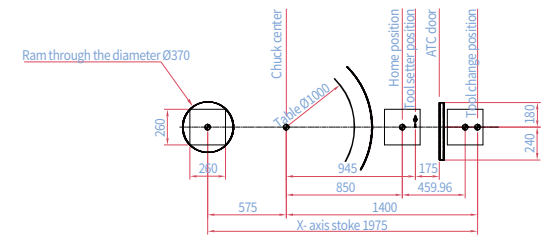

\* This working range diagram for Capto-C6 Horizontal & Vertical Head. If the user using another tool holder, please contact DN Solutions.

## PUMA VTR1012F/FM

## PUMA VTR1216F/FM

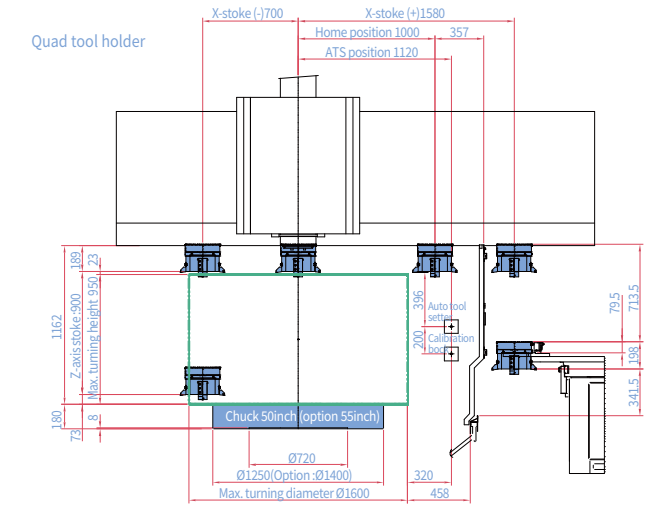
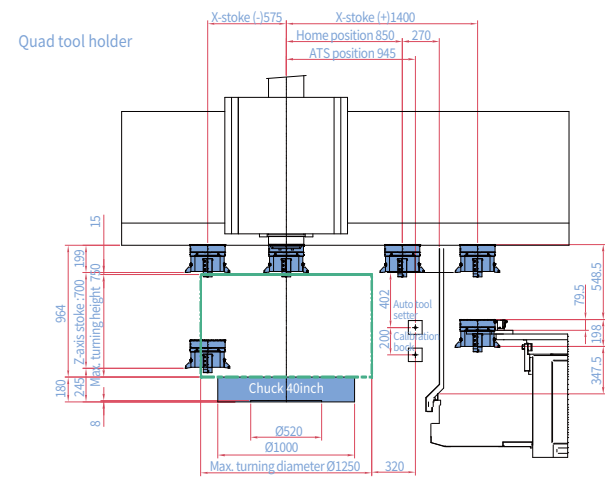
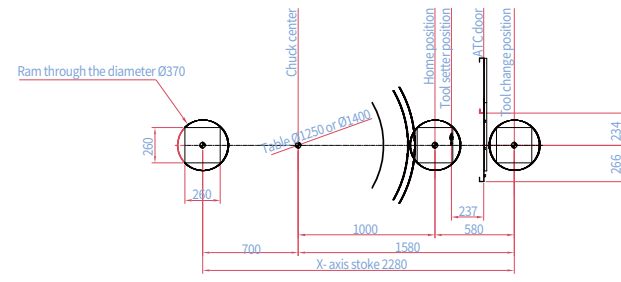
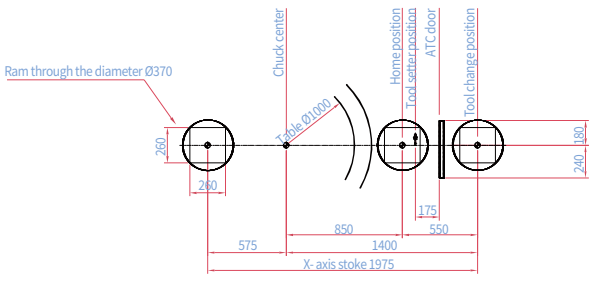

\* This working range diagram for QUAD tool holder. If the user using another tool holder, please contact DN Solutions.



# WORKING RANGE DIAGRAM

## PUMA VTR1216/M

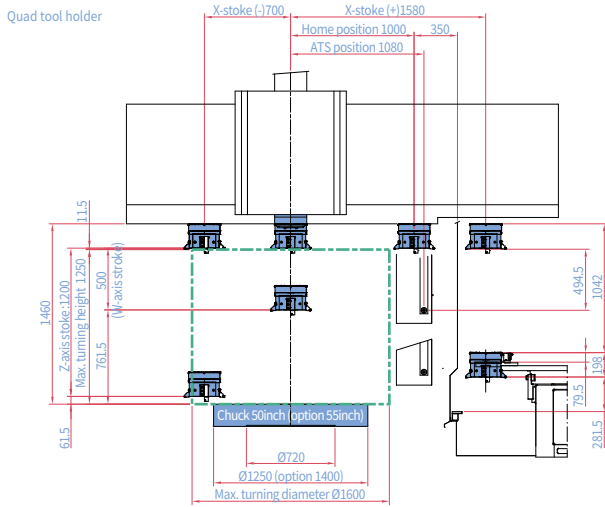
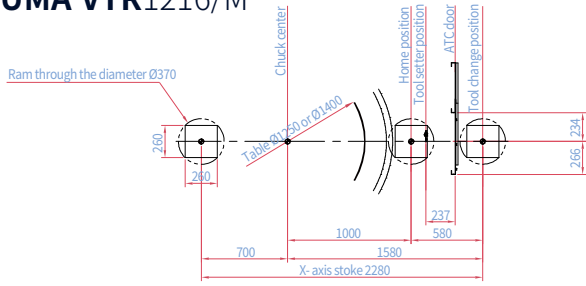

## PUMA VTR1620/M

Unit : mm (inch)

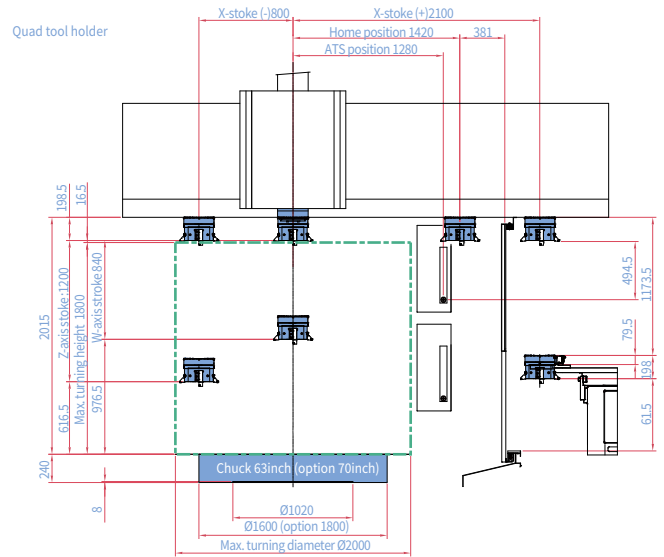
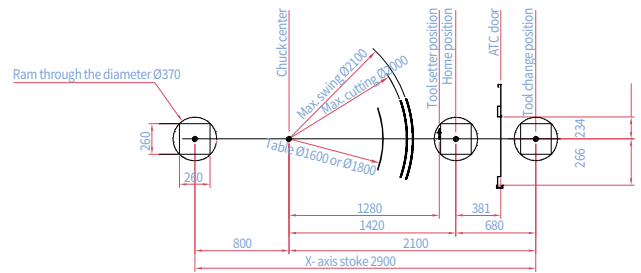

## PUMA VTR2025/M

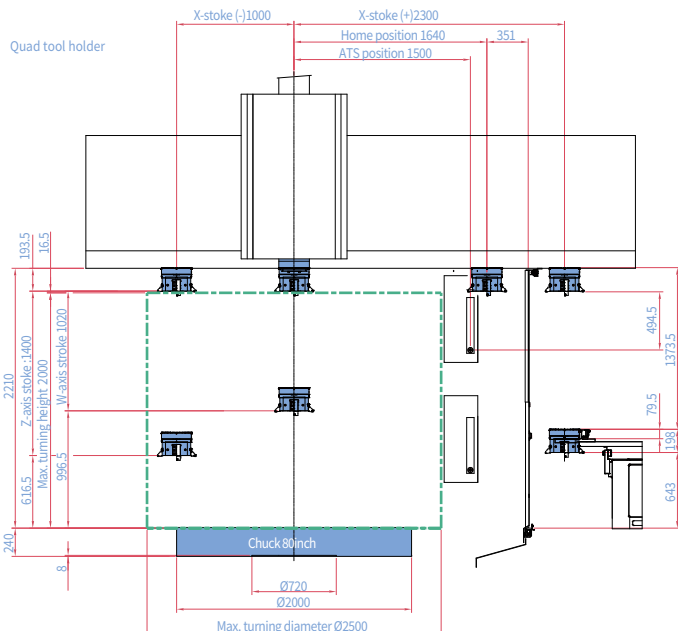
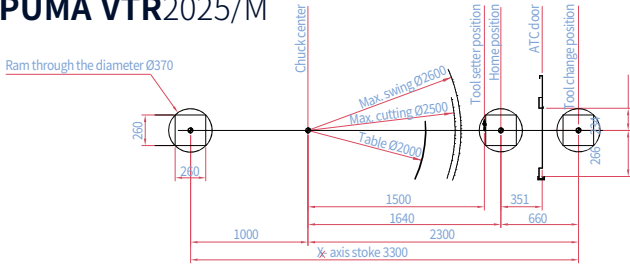

# TOOL INTERFERENCE DIAGRAM

[caution]

Normal Type

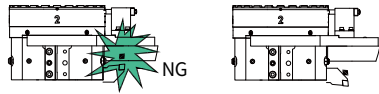

Long Type

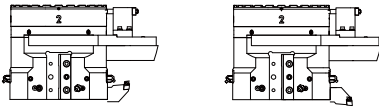

## PUMA VTR1012FC/1216FC (60-ATC)

Unit : mm (inch)

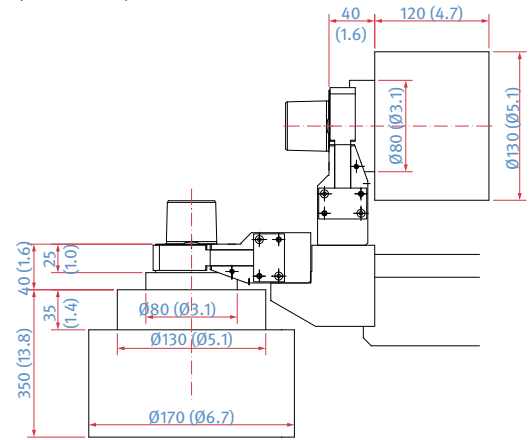

## PUMA VTR1012F/1216F (12-ATC)

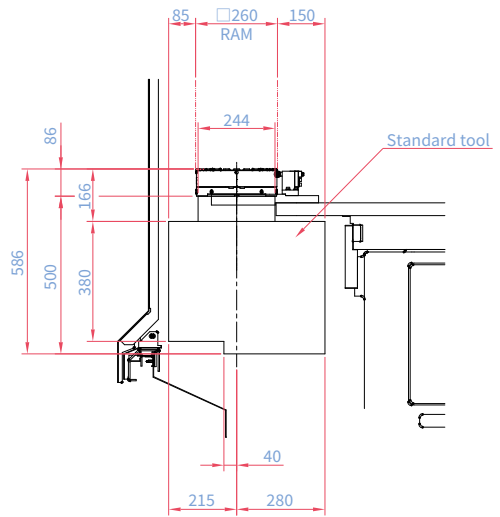
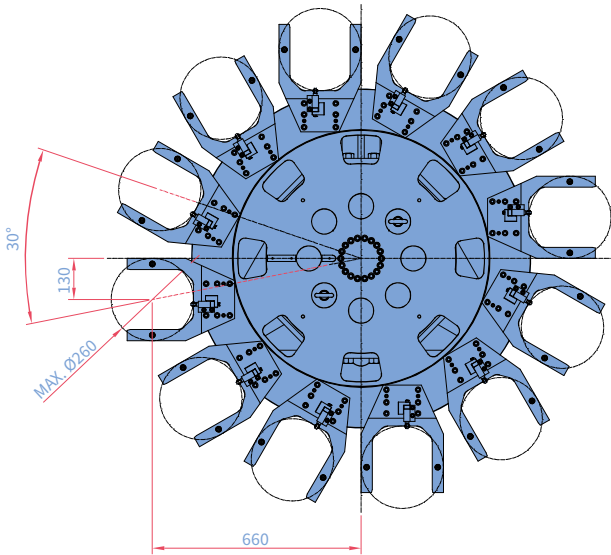

## PUMA VTR1012FM/1216FM (15-ATC)

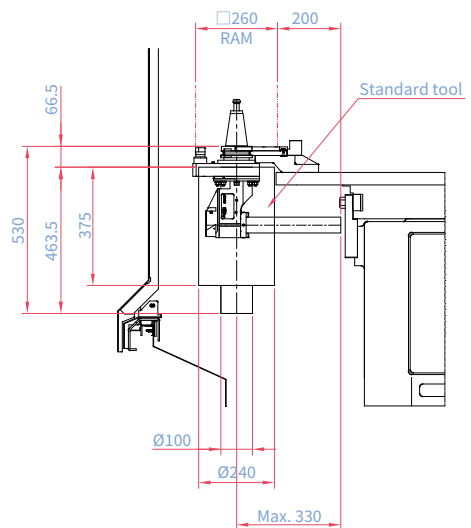
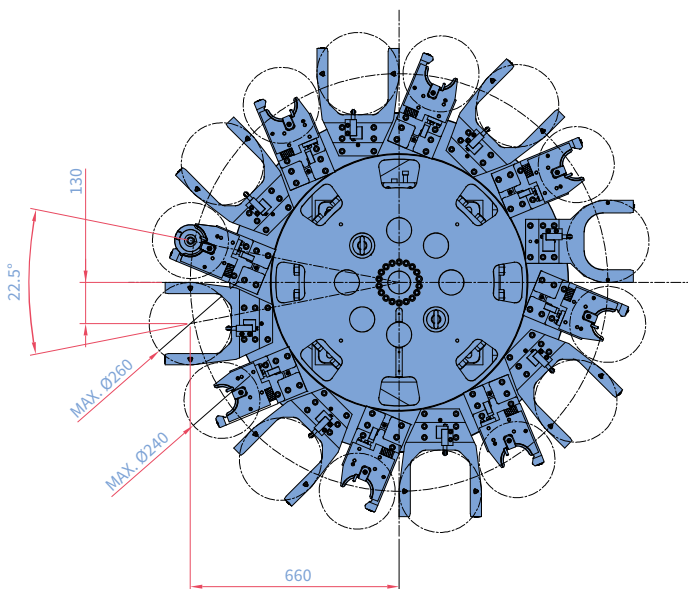

# TOOL INTERFERENCE DIAGRAM

Unit : mm (inch)

**PUMA VTR1216**  
(12-ATC)

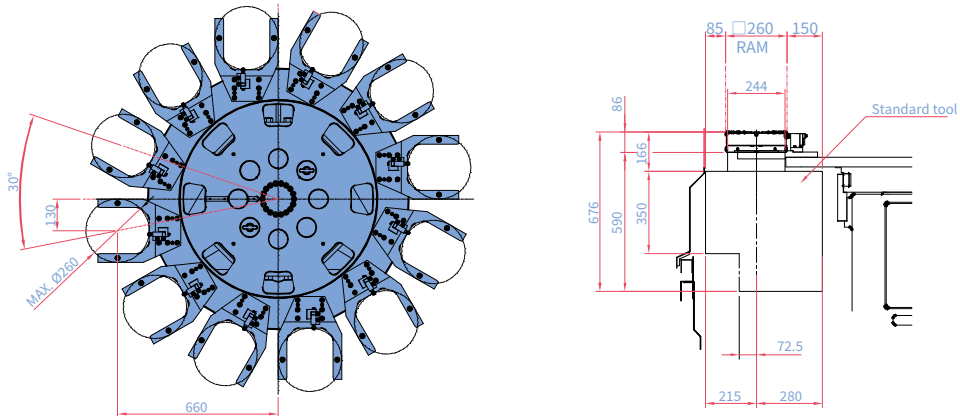

**PUMA VTR1216M**  
(15-ATC)

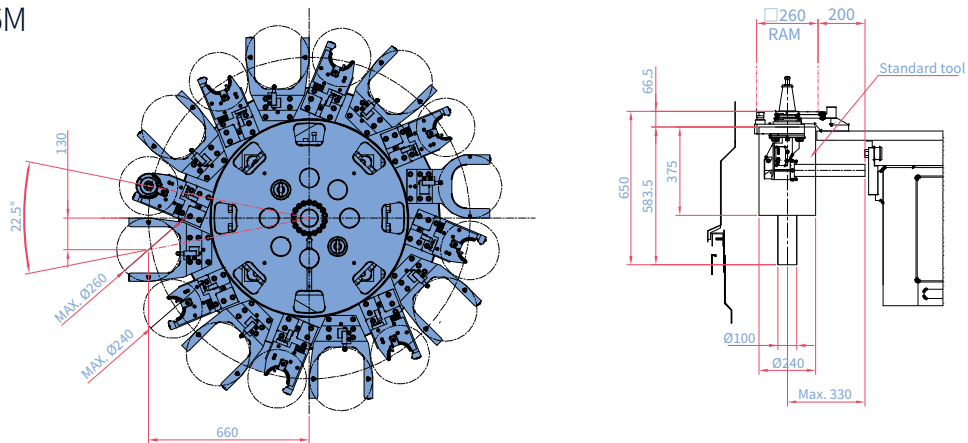

**PUMA VTR1620/2025**  
(12-ATC)

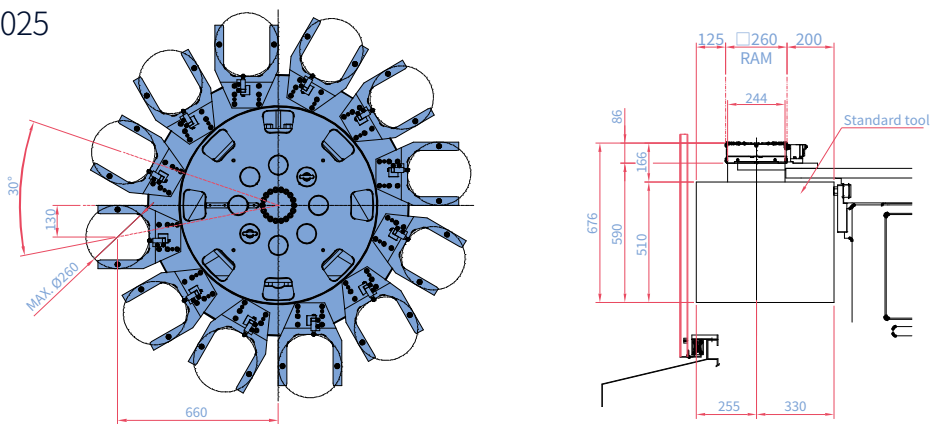

**PUMA VTR1620M/2025M**  
(15-ATC)

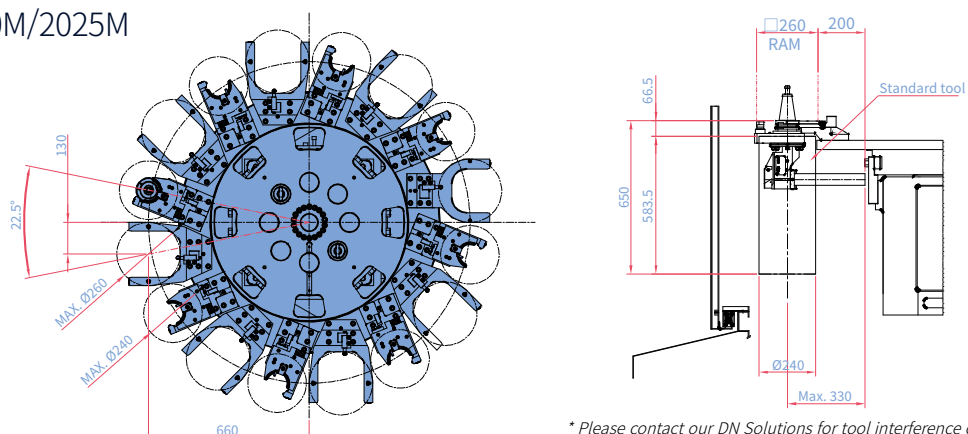

\* Please contact our DN Solutions for tool interference other than standard ATC.

# MACHINE SPECIFICATIONS

**PUMA VTR1012F/FC/FM, 1216/F/FC/FM/M**

Description		Unit	PUMA VTR 1012F	PUMA VTR 1012FM	PUMA VTR 1012FC	PUMA VTR 1216F	PUMA VTR 1216FC	PUMA VTR 1216FM	PUMA VTR 1216	PUMA VTR 1216M	
Capacity	Swing over bed	mm (inch)	1350 (53.1)		1300 (25.0)	1700 (25.0)		1700 (25.0)			
	Recom. turning diameter	mm (inch)	1000 (39.4)			1250 (49.2)		1250 (49.2)			
	Max. turning diameter	mm (inch)	1250 (49.2)			1600 (63.0)		1600 (63.0)			
	Max. turning height	mm (inch)	750 (29.5)	695 (27.4)	950 (37.4)	895 (35.2)	950 (37.4)	1250 (49.2)			
	Max. allowable workpiece weight (including chuck weight)	kg (lb)	6000 (13227.5)			8000 (17636.7)		8000 (17636.7)			
Travels	Travel distance	X-axis	-575 ~ 850 (-22.6~33.5)			-700 ~ 1000 (-27.6~39.4)		-700 ~ 1000 (-27.6~39.4)			
		Z-axis	700 (27.6)			900 (35.4)		1200 (47.2)			
		W-axis	-	-	-	-	-	500 (250 x 2step) (19.7(9.8x2step))			
	Rapid traverse Rate	X-axis	12 (472.4)			12 (472.4)		12 (472.4)			
		Z-axis	10 (393.7)			10 (393.7)		10 (393.7)			
		W-axis	-	-	-	-	-	-			
Spindle	Max. spindle speed	r/min	600			400		400			
	Motor power	Std.(S3 60%/cont.)	45/37 (60.3/49.6)			45/37 (60.3/49.6)		45/37 (60.3/49.6)			
		Opt1(High torque, S3 25%/60%/cont.)	70/45/37 (93.9/60.3/49.6)			70/45/37 (93.9/60.3/49.6)		70/45/37 (93.9/60.3/49.6)			
		Opt2(High torque /Power, S3 25%/60%/cont.)	-	-	-	-	-	75/60 (100.6/80.5)	-	75/60 (100.6/80.5)	
	Max. torque	Std.	12354 (9117.3)			20557 (15171.1)		20557 (15171.1)			
		Opt1(High torque)	19217 (14182.1)			31997 (23613.8)		31997 (23613.8)			
		Opt2(High torque/Power)	-	-	-	-	-	31147 (22986.5)	-	31147 (22986.5)	
Min. spindle indexing angle(C-axis)	deg	-	0.001	-	-	-	0.001	-	0.001		
Tool magazine	Tool storage capa. (Max.)	ea	12 {24}	15{23,33}	60 (CAPTO C6 or C8)	12 {24}	60 (CAPTO C6 or C8)	15{23,33}	12 {24}	15 {23, 33}	
	Magazine indexing time(1st)	s	4			4		4			
	Max. tool length	Vertical	mm (inch)	Turning 500 (19.7)	Turning : 500 (19.7) Milling : 530 (20.9)	Turning 160 (6.3)	Turning 500 (19.7)	Turning 160 (6.3)	Turning : 500 (19.7) Milling : 530 (20.9)	Turning 590 (23.2)	Turning : 590 (23.2) Milling : 650 (25.6)
		Horizontal**		Turning 150 (5.9)	Turning : 150 (5.9) Milling : 200(7.9)	Turning 350 (13.8)	Turning 150 (5.9)	Turning 360 (14.2)	Turning : 150 (5.9) Milling : 200(7.9)	Turning 150 (5.9)	Turning : 150(19.7) Milling : 200(7.9)
Tooling	OD/Face tool size	mm (inch)	32 (1.3)		-	32{40} (1.3{1.6})	-	32{40} (1.3{1.6})			
	ID tool size	mm (inch)	32 (1.3)		-	32 (1.3)	-	32 (1.3)			
	Boring Bar dia.	mm (inch)	ø100 (ø3.9)		-	ø100 (ø3.9)	-	ø100 (ø3.9)			
	Tool clamping force	kN	78.5	Turning : 78.5 Milling : 20.0	-	78.5	-	Turning : 78.5 Milling : 23.5	78.5	Turning : 78.5 Milling : 23.5	
RAM	RAM size	mm (inch)	260 x 260 (10.2 X 10.2)			260 x 260 (10.2 X 10.2)		260 x 260 (10.2 X 10.2)			
Milling spindle	Max. spindle speed	r/min	-	3000	-	-	-	3000	-	3000	
	Motor power	Std.(S325%/60%/cont.)	-	18.5/15/11	-	-	-	18.5/15/11 (24.8/20.1/14.8)	-	18.5/15/11 (24.8/20.1/14.8)	
		Opt(High torque/Power, S3 25%/60%/cont.)	-	-	-	-	-	25/18.5/15 (33.5/24.8/20.1)	-	25/18.5/15 (33.5/24.8/20.1)	
	Max. spindle torque	Std.	-	674	-	-	-	674 (497.4)	-	674 (497.4)	
Opt(High torque/Power)		-	-	-	-	-	1273 (939.5)	-	1273 (939.5)		
Power source	Power consumption	kVA	112.2			112.2		112.2			
Machine dimensions	Length	mm (inch)	4970 (195.7)		5545 (218.3)	5590 (220.1)	5965 (234.8)	5590 (220.1)			
	Width	mm (inch)	3147 (123.9)		3987 (157.0)	4066 (160.1)	4115 (162.0)	4066 (160.1)			
	Height	mm (inch)	4768 (187.7)			5065 (199.4)		5065 (199.4)	5650 (222.4)		
	Weight	kg (lb)	26000 (57319.3)			27500 (60626.2)		28000 (61728.5)	29500 (65035.4)	30000 (66137.7)	
Control	CNC system	DN Solutions-FANUC i PLUS									

# MACHINE SPECIFICATIONS

## PUMA VTR1620/1620M/2025/2025M

Description		Unit	PUMA VTR1620	PUMA VTR1620M	PUMA VTR2025	PUMA VTR2025M		
Capacity	Swing over bed	mm (inch)	2100 (82.7)		2500 (98.4)			
	Recom. turning diameter	mm (inch)	1600 (63.0)		2000 (78.7)			
	Max. turning diameter	mm (inch)	2000 (78.7)		2500 (98.4)			
	Max. turning height	mm (inch)	1800 (70.9)		2000 (78.7)			
	Max. allowable workpiece weight (including chuck weight)	kg (lb)	10000 (22045.9)		15000 (33068.9)			
Travels	Travel distance	X-axis	-800 ~ 1420 (-31.5~55.9)		-1000~1640 (-39.4~64.6)			
		Z-axis	1200 (47.2)		1400 (55.1)			
		W-axis	840(280 x 3step) (33.1(11.0x3step))		1020(340x3step) ((40.2)119.7x3step)			
	Rapid traverse Rate	X-axis	m/min (ipm)	12 (472.4)		10 (393.7)		
		Z-axis	m/min (ipm)	10 (393.7)		10 (393.7)		
		W-axis	m/min (ipm)	-	-	-	-	
Spindle	Max. spindle speed		r/min		300		200	
	Motor power	Std.(S3 60%/cont.)	kW (Hp)		45/37 (60.3/49.6)		75/60(100.6/80.5)	
		Opt1(High torque, S3 25%/60%/cont.)	kW (Hp)		70/45/37 (93.9/60.3/49.6)		-	
		Opt2(High torque/Power, S3 25%/60%/cont.)	kW (Hp)		-		75/60 (100.6/80.5)	
	Max. torque	Std.	N·m (ft-lbs)		24668 (18205.0)		46720 (34479.4)	
		Opt1(High torque)	N·m (ft-lbs)		38373 (28319.3)		-	
		Opt2(Hightorque/Power)	N·m (ft-lbs)		-		37376 (27583.5)	
Min. spindle indexing angle(C-axis)		deg		-		0.001		
Tool magazine	Tool storage capa. (Max.)		ea		12 {24}		15 {23, 33}	
	Magazine indexing time(1st)		s		4		4	
	Max. tool length	Vertical	mm (inch)		Turning 590 (23.2)		Turning : 590 (23.2) Milling : 650 (25.6)	
		Horizontal**	mm (inch)		Turning 200(7.9)		Turning : 200(7.9) Milling : 200(7.9)	
Tooling	OD/Face tool size		mm (inch)		32{40} (1.3{1.6})		32{40} (1.3{1.6})	
	ID tool size		mm (inch)		32 (1.3)		32 (1.3)	
	Boring bar dia.		mm (inch)		ø100 (ø3.9)		ø100 (ø3.9)	
	Tool clamping force		kN		78.5		Turning : 78.5 Milling : 23.5	
RAM	RAM size		mm (inch)		260 x 260 (10.2 X 10.2)		260 x 260 (10.2 X 10.2)	
Milling spindle	Max. spindle speed		r/min		-		3000	
	Motor power	Std.(S325%/60%/cont.)	kW (Hp)		-		18.5/15/11 (24.8/20.1/14.8)	
		Opt(High torque/Power, S3 25%/60%/cont.)	kW (Hp)		-		35/26/22 (46.9/34.9/29.5)	
	Max. spindle torque	Std.	N·m (ft-lbs)		-		674 (497.4)	
Opt(High torque/Power)		N·m (ft-lbs)		-		1782 (1315.1)		
Power source	Power consumption		kVA		112.2		120	
Machine dimensions	Length		mm (inch)		6500 (255.9)		7296 (287.2)	
	Width		mm (inch)		4757 (187.3)		4836 (190.4)	
	Height		mm (inch)		6345 (249.8)		7600 (299.2)	
	Weight		kg (lb)		39000 (85979.0)		40000 (88183.6)	
Control	CNC system		DN Solutions-FANUC i PLUS					

The DN Solutions promise, MACHINE GREATNESS, has two important meanings. The first is simple: DN Solutions makes great machines. The second is a challenge to our end-users. With a product line that is this comprehensive, accurate and reliable, we equip our customers to machine greatness. The big question: ***Why should you choose DN Solutions over other options?***

Here's why...



**MACHINE  
GREATNESS™**



WHAT YOU MAKE AND HOW YOU MAKE IT MATTERS—SO MAKE IT GREAT WITH DN SOLUTIONS.

### UNBEATABLE MACHINES

You won't find a more comprehensive range or a better combination of value, performance and reliability anywhere else.

### ROBUST PRODUCT LINE

We offer an impressive range of machine models and hundreds of configurations. Whatever your machining needs and requirements, there's a DN Solutions for you.

### READILY AVAILABLE - ANYWHERE IN THE WORLD

Machining centres (including 5-axis machines), lathes, multi-tasking turning centres and mill-turn machines, and horizontal borers with best-in-class specifications are all available...ready to install.

### EXPERT SERVICE

Our dedicated, experienced and knowledgeable team is totally committed to improving your productivity, growth and success.

# RESPONDING TO CUSTOMERS ANYTIME, ANYWHERE

## DN Solutions Global Network

DN Solutions provides systems-based professional support services, before and after the machine tool sale, by responding quickly and efficiently to customers. By supplying spare parts, product training, field service and technical support, we provide the expert care, attention and assistance our customers expect from a market leader.

Global sales and service support network		<b>51</b>	<b>Technical centers</b> Technical center, Sales support, Service support, Parts support
<b>4</b>	Corporations	<b>200</b>	<b>Service posts</b>
<b>155</b>	Dealer networks	<b>3</b>	<b>Factories</b>



## CUSTOMER SUPPORT AND SERVICES

**We're there for you whenever you need us.**

We help our customers operate at maximum efficiency by providing them with a range of tried, tested and trusted services - from pre-sales consultancy to post-sales support.



### Field services

- On-site service
- Machine installation and testing
- Scheduled preventive maintenance
- Machine repair service



### Parts supply

- Supplying a wide range of original DN Solutions spare parts
- Parts repair service



### Training

- Programming, machine setup and operation
- Electrical and mechanical maintenance
- Applications engineering



### Technical support

- Supports machining methods and technology
- Responds to technical queries
- Provides technical consultancy



[dn-solutions.com](http://dn-solutions.com)

**Head Office**

22F T Tower, 30, Sowol-ro 2-gil  
Jung-gu, Seoul, Korea, 04637  
Tel: +82-2-6972-0370/0350  
Fax: +82-2-6972-0400

**DN Solutions America**

19A Chapin Road, Pine Brook  
New Jersey 07058, United States  
Tel: +1-973-618-2500  
Fax: +1-973-618-2501

**DN Solutions Europe**

Emdener Strasse 24, D-41540  
Dormagen, Germany  
Tel: +49-2133-5067-100  
Fax: +49-2133-5067-111

**DN Solutions India**

No.82, Jakkuar Village  
Yelahanka Hobli, Bangalore-560064  
Tel: + 91-80-2205-6900  
E-mail: [india@dncompany.com](mailto:india@dncompany.com)

**DN Solutions China**

Room 101,201,301, Building 39 Xinzhuan  
Highway No.258 Songjiang District  
China Shanghai (201612)  
Tel: +86 21-5445-1155  
Fax: +86 21-6405-1472

**Sales inquiry**

[sales@dncompany.com](mailto:sales@dncompany.com)

\* For more details, please contact DN Solutions.

\* Specifications and information contained within this catalogue may be changed without prior notice.